



DEPT. OF MECHANICAL ENGINEERING

**TRIDENT ACADEMY OF TECHNOLOGY,
BHUBANESWAR**

LECTURE NOTES

ON

ENGINEERING MECHANICS

B. Tech

1st / 2nd Semester

By

Dr. Ajay Kumar Sahoo

Professor

Department of MECH

ENGINEERING MECHANICS

Module-I

(10Hours)

Concurrent forces on a plane: Composition, resolution and equilibrium of concurrent coplanar forces, method of moment. General case of forces on a plane: Composition and equilibrium of forces in a plane, plane trusses, method of joints and method of sections.

Module-II

(6 Hours)

Friction: Fundamentals and Problems involving friction, Ladder, Wedges. Principle of virtual work.

Module - III

(8Hours)

Parallel forces on a plane: General case of parallel forces, center of parallel forces and center of gravity, Centroid of plane and composite figures, Theorems of Pappus and Guildins. Moment of inertia: Plane figure with respect to an axis in its plane and perpendicular to the plane, Polar moment of inertia, parallel axis theorem.

Module – IV

(8 Hours)

Rectilinear translation: Kinematics, Principle of dynamics, D'Alembert's Principle, Principle of work and energy for a particle and a rigid body, Conservation of energy, Principle of impulse and momentum for a particle and a rigid body, Conservation of momentum, System of rigid bodies, Impact, direct and central impact, coefficient of restitution.

Module – V

(8 Hours)

Curvilinear translation: Kinematics, Equation of motion, Projectile, D'Alembert's principle of curvilinear motion. Kinematics of rotation of rigid body.

Essential Reading:

1. Engineering Mechanics: S. Timoshenko, D.H. Young, J.V. Rao, Sukumar Pati, 5th Edition, 2017 McGraw Hill.

Supplementary Reading:

1. Engineering Mechanics, Static and Dynamics, J. L. Meriam and L.G.Kraige, 9th Edition, 2021, John Wiley & Sons, Inc.
2. Fundamental of Engineering mechanics, S Rajesekharan & G ShankaraSubramaniam, 3rd Edition, 2017, S. Chand .
3. Engineering mechanics: K. L. Kumar and VeenuKumar, 4th Edition, 2017, Tata MC Graw Hill.

Upon completion of the subject the students will be able to:

CO1	Ability to analyze objects in static equilibrium including the determination of reactions, forces and moments.
CO2	Enrich fundamental concept of friction and demonstrate the analytical skills to solve the problems involving friction.
CO3	Assimilate the knowledge for determination of centroid and second moment of area of sections and their engineering applications.
CO4	To analyze the work done by forces, the energy transferred from one object to other and apply principle of work and energy conservation for realistic (/Practical) engineering problems.
CO5	Identify the various parameters in projectile motion. Apply the principle of dynamics to analyze the curvilinear motion of rigid bodies.

Course Articulation Matrix

	PO1	PO2	PO3	PO4	PO5	PO6	PO7	PO8	PO9	PO10	PO11	PO12
CO1	3	3	2	1	2	-	-	-	3	1	-	1
CO2	3	3	2	1	2	-	-	-	3	1	-	1
CO3	3	3	2	1	2	-	-	-	3	1	-	1
CO4	3	3	2	1	2	-	-	-	3	1	-	1
CO5	3	3	2	1	2	-	-	-	3	1	-	1

Program Articulation Matrix Row for this Course

	PO1	PO2	PO3	PO4	PO5	PO6	PO7	PO8	PO9	PO10	PO11	PO12
CO	3	3	2	1	2	-	-	-	3	1	-	1

UNIT 1

INTRODUCTION TO ENGINEERING MECHANICS

ENGINEERING MECHANICS: The subject of Engineering Mechanics is that branch of Applied Science, which deals with the laws and principles of Mechanics, along with their applications to engineering problems.

The subject of Engineering Mechanics may be divided into the following two main groups:
1. Statics, and 2. Dynamics

STATICS: It is that branch of Engineering Mechanics, which deals with the forces and their effects, while acting upon the bodies at rest.

DYNAMICS: It is that branch of Engineering Mechanics, which deals with the forces and their effects, while acting upon the bodies in motion. The subject of Dynamics may be further sub-divided into the following two branches:

1. Kinetics, and 2. Kinematics

KINETICS: It is the branch of Dynamics, which deals with the bodies in motion due to the application of forces.

KINEMATICS: It is that branch of Dynamics, which deals with the bodies in motion, without any reference to the forces which are responsible for the motion.

RIGID BODY: A rigid body (also known as a rigid object) is a solid body in which deformation is zero or so small it can be neglected. The distance between any two given points on a rigid body remains constant in time regardless of external forces exerted on it. A rigid body is usually considered as a continuous distribution of mass.

FORCE: It is defined as an agent which produces or tends to produce, destroys or tends to destroy motion. *e.g.*, a horse applies force to pull a cart and to set it in motion. Force is also required to work on a bicycle pump. In this case, the force is supplied by the muscular power of our arms and shoulders.

SYSTEM OF FORCES: When two or more forces act on a body, they are called to form a system of forces. Following systems of forces are important from the subject point of view;

1. **Coplanar forces:** The forces, whose lines of action lie on the same plane, are known as coplanar forces.

2. **Collinear forces:** The forces, whose lines of action lie on the same line, are known as collinear forces

3. **Concurrent forces:** The forces, which meet at one point, are known as concurrent forces. The concurrent forces may or may not be collinear.

4. **Coplanar concurrent forces:** The forces, which meet at one point and their lines of action also lie on the same plane, are known as coplanar concurrent forces.

5. **Coplanar non-concurrent forces:** The forces, which do not meet at one point, but their lines of action lie on the same plane, are known as coplanar non-concurrent forces.

6. **Non-coplanar concurrent forces:** The forces, which meet at one point, but their lines of

action do not lie on the same plane, are known as non-coplanar concurrent forces.

7. Non-coplanar non-concurrent forces: The forces, which do not meet at one point and their lines of action do not lie on the same plane, are called non-coplanar non-concurrent forces.

CHARACTERISTIC OF A FORCE: In order to determine the effects of a force, acting on a body, we must know the following characteristics of a force:

1. Magnitude of the force (*i.e.*, 100 N, 50 N, 20 kN, 5 kN, etc.)
2. The direction of the line, along which the force acts (*i.e.*, along OX , OY , at 30° North of East etc.). It is also known as line of action of the force.
3. Nature of the force (*i.e.*, whether the force is push or pull). This is denoted by placing an arrow head on the line of action of the force.
4. The point at which (or through which) the force acts on the body

EFFECTS OF A FORCE: A force may produce the following effects in a body, on which it acts:

1. It may change the motion of a body. *i.e.* if a body is at rest, the force may set it in motion. And if the body is already in motion, the force may accelerate it.
2. It may retard the motion of a body.
3. It may retard the forces, already acting on a body, thus bringing it to rest or in equilibrium.
4. It may give rise to the internal stresses in the body, on which it acts.

PRINCIPLE OF TRANSMISSIBILITY: It states, "If a force acts at any point on a rigid body, it may also be considered to act at any other point on its line of action, provided this point is rigidly connected with the body."

PRINCIPLE OF SUPERPOSITION: This principle states that the combined effect of force system acting on a particle or a rigid body is the sum of effects of individual forces.

ACTION AND REACTION FORCE: Forces always act in pairs and always act in opposite directions. When you push on an object, the object pushes back with an equal force. Think of a pile of books on a table. The weight of the books exerts a downward force on the table. This is the action force. The table exerts an equal upward force on the books. This is the reaction force.

FREE BODY DIAGRAM: A free body diagram is a graphical illustration used to visualize the applied forces, moments, and resulting reactions on a body in a given condition. They depict a body or connected bodies with all the applied forces and moments, and reactions, which act on the body. The body may consist of multiple internal members (such as a truss), or be a compact body (such as a beam). A series of free bodies and other diagrams may be necessary to solve complex problems.

RESOLUTION OF A FORCE: The process of splitting up the given force into a number of components, without changing its effect on the body is called resolution of a force. A force is, generally, resolved along two mutually perpendicular directions.

COMPOSITION OF FORCES: The process of finding out the resultant force, of a number of given forces, is called composition of forces or compounding of forces.

RESULTANT FORCE: If a number of forces, P, Q, R ... etc. are acting simultaneously on a particle, then it is possible to find out a single force which could replace them i.e., which would produce the same effect as produced by all the given forces. This single force is called resultant force and the given forces R ...etc. are called component forces

METHODS FOR THE RESULTANT FORCE:

Though there are many methods for finding out the resultant force of a number of given forces, yet the following are important from the subject point of view :

1. Analytical method.
2. Method of resolution.

ANALYTICAL METHOD FOR RESULTANT FORCE:

The resultant force, of a given system of forces, may be found out analytically by the following methods :

1. Parallelogram law of forces.
2. Method of resolution.

PARALLELOGRAM LAW OF FORCES:

It states, "If two forces, acting simultaneously on a particle, be represented in magnitude and direction by the two adjacent sides of a parallelogram ; their resultant may be represented in magnitude and direction by the diagonal of the parallelogram, which passes through their point of intersection."

Mathematically, resultant force,

$$R = \sqrt{F_1^2 + F_2^2 + 2 F_1 F_2 \cos \theta}$$

and
$$\tan \alpha = \frac{F_2 \sin \theta}{F_1 + F_2 \cos \theta}$$

where F_1 and F_2 = Forces whose resultant is required to be found out,
 θ = Angle between the forces F_1 and F_2 , and
 α = Angle which the resultant force makes with one of the forces (say F_1).

EXAMPLE: Two forces of 100 N and 150 N are acting simultaneously at a point. What is the resultant of these two forces, if the angle between them is 45° ?

Solution. Given : First force (F_1) = 100 N; Second force (F_2) = 150 N and angle between F_1 and F_2 (θ) = 45° .

We know that the resultant force,

$$\begin{aligned} R &= \sqrt{F_1^2 + F_2^2 + 2 F_1 F_2 \cos \theta} \\ &= \sqrt{(100)^2 + (150)^2 + 2 \times 100 \times 150 \cos 45^\circ} \text{ N} \\ &= \sqrt{10\,000 + 22\,500 + (30\,000 \times 0.707)} \text{ N} \\ &= 232 \text{ N} \quad \text{Ans.} \end{aligned}$$

EXAMPLE: Find the magnitude of the two forces, such that if they act at right angles, their resultant is 10 N . But if they Act at 60°, their resultant is 13 N .

Solution. Given : Two forces = F_1 and F_2 .

First of all, consider the two forces acting at right angles. We know that when the angle between the two given forces is 90°, then the resultant force (R)

$$\sqrt{10} = \sqrt{F_1^2 + F_2^2}$$

or $10 = F_1^2 + F_2^2$... (Squaring both sides)

Similarly, when the angle between the two forces is 60°, then the resultant force (R)

$$\sqrt{13} = \sqrt{F_1^2 + F_2^2 + 2F_1 F_2 \cos 60^\circ}$$

∴ $13 = F_1^2 + F_2^2 + 2F_1 F_2 \times 0.5$... (Squaring both sides)

or $F_1 F_2 = 13 - 10 = 3$... (Substituting $F_1^2 + F_2^2 = 10$)

We know that $(F_1 + F_2)^2 = F_1^2 + F_2^2 + 2F_1 F_2 = 10 + 6 = 16$

∴ $F_1 + F_2 = \sqrt{16} = 4$... (i)

Similarly $(F_1 - F_2)^2 = F_1^2 + F_2^2 - 2F_1 F_2 = 10 - 6 = 4$

∴ $F_1 - F_2 = \sqrt{4} = 2$... (ii)

Solving equations (i) and (ii),

$$F_1 = 3 \text{ N} \quad \text{and} \quad F_2 = 1 \text{ N} \quad \text{Ans.}$$

RESOLUTION OF A FORCE: The process of splitting up the given force into a number of components, without changing its effect on the body is called resolution of a force. A force is, generally, resolved along two mutually perpendicular directions. In fact, the resolution of a force is the reverse action of the addition of the component vectors.

PRINCIPLE OF RESOLUTION: It states, “The algebraic sum of the resolved parts of a no. of forces, in a given direction, is equal to the resolved part of their resultant in the same direction.”

Note: In general, the forces are resolved in the vertical and horizontal directions.

METHOD OF RESOLUTION:

- Resolve all the forces horizontally and find the algebraic sum of all the horizontal components .
- Resolve all the forces vertically and find the algebraic sum of all the vertical components
- The resultant R of the given forces will be given by the equation;

$$R = \sqrt{(\sum H)^2 + (\sum V)^2}$$

- The resultant force will be inclined at an angle , with the horizontal, such that

$$\tan \theta = \frac{\sum V}{\sum H}$$

EXAMPLE: A triangle ABC has its side AB = 40 mm along positive x-axis and side BC = 30 mm along positive y-axis. Three forces of 40 N, 50 N and 30 N act along the sides AB, BC and CA respectively. Determine magnitude of the resultant of such a system of forces.

Solution. The system of given forces is shown in Fig. 2.3.

From the geometry of the figure, we find that the triangle ABC is a right angled triangle, in which the *side AC = 50 mm. Therefore

$$\sin \theta = \frac{30}{50} = 0.6$$

and

$$\cos \theta = \frac{40}{50} = 0.8$$

Resolving all the forces horizontally (*i.e.*, along AB),

$$\begin{aligned} \sum H &= 40 - 30 \cos \theta \\ &= 40 - (30 \times 0.8) = 16 \text{ N} \end{aligned}$$

and now resolving all the forces vertically (*i.e.*, along BC)

$$\begin{aligned} \sum V &= 50 - 30 \sin \theta \\ &= 50 - (30 \times 0.6) = 32 \text{ N} \end{aligned}$$

We know that magnitude of the resultant force,

$$R = \sqrt{(\sum H)^2 + (\sum V)^2} = \sqrt{(16)^2 + (32)^2} = 35.8 \text{ N Ans.}$$

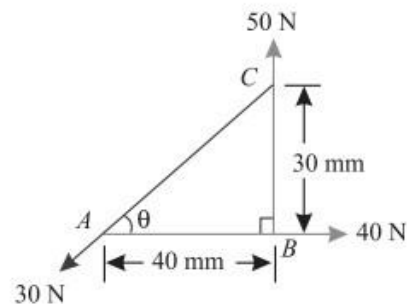

LAWS FOR THE RESULTANT FORCE:

The resultant force, of a given system of forces, may also be found out by the following laws

1. Triangle law of forces. 2. Polygon law of forces.

TRIANGLE LAW OF FORCES:

It states, "If two forces acting simultaneously on a particle, be represented in magnitude and direction by the two sides of a triangle, taken in order ; their resultant may be represented in magnitude and direction by the third side of the triangle, taken in opposite order."

POLYGON LAW OF FORCES:

It is an extension of Triangle Law of Forces for more than two forces, which states, "If a number of forces acting simultaneously on a particle, be represented in magnitude and direction, by the sides of a polygon taken in order ; then the resultant of all these forces may be represented, in magnitude and direction, by the closing side of the polygon, taken in opposite order."

GRAPHICAL (VECTOR) METHOD FOR THE RESULTANT FORCE:

It is another name for finding out the magnitude and direction of the resultant force by the polygon law of forces. It is done as discussed below:

- **Construction of space diagram (position diagram):** It means the construction of a diagram showing the various forces (or loads) along with their magnitude and lines of action.

- **Use of Bow's notations:** All the forces in the space diagram are named by using the Bow's notations. It is a convenient method in which every force (or load) is named by two capital letters, placed on its either side in the space diagram.
- **Construction of vector diagram (force diagram):** It means the construction of a diagram starting from a convenient point and then go on adding all the forces vectorially one by one (keeping in view the directions of the forces) to some suitable scale. Now the closing side of the polygon, taken in opposite order, will give the magnitude of the resultant force (to the scale) and its direction.

EXAMPLE: A particle is acted upon by three forces equal to 50 N, 100 N and 130 N, along the three sides of an equilateral triangle, taken in order. Find graphically the Magnitude and direction of the resultant force.

Solution. The system of given forces is shown in Fig. 2.8 (a)

First of all, name the forces according to Bow's notations as shown in Fig. 2.8 (a). The 50 N force is named as *AD*, 100 N force as *BD* and 130 N force as *CD*.

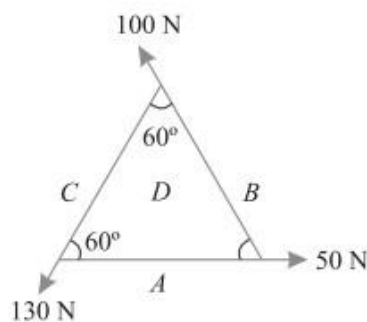

(a) Space diagram

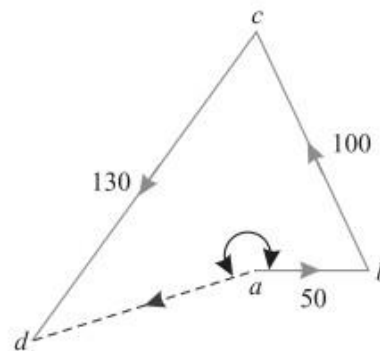

(b) Vector diagram

Now draw the vector diagram for the given system of forces as shown in Fig. 2.8 (b) and as discussed below :

1. Select some suitable point *a* and draw *ab* equal to 50 N to some suitable scale and parallel to the 50 N force of the space diagram.
2. Through *b*, draw *bc* equal to 100 N to the scale and parallel to the 100 N force of the space diagram.
3. Similarly through *c*, draw *cd* equal to 130 N to the scale and parallel to the 130 N force of the space diagram.
4. Join *ad*, which gives the magnitude as well as direction of the resultant force.
5. By measurement, we find the magnitude of the resultant force is equal to 70 N and acting at an angle of 200° with *ab*. **Ans.**

MOMENT OF A FORCE: It is the turning effect produced by a force, on the body, on which it acts. The moment of a force is equal to the product of the force and the perpendicular distance of the point, about which the moment is required and the line of action of the force.

Mathematically, moment,

$$M = P \times l$$

where P = Force acting on the body, and

l = Perpendicular distance between the point, about which the moment is required and the line of action of the force.

GRAPHICAL REPRESENTATION OF A MOMENT: Consider a force P represented, in magnitude and direction, by the line AB . Let O be a point, about which the moment of this force is required to be found out, as shown in Fig. From O , draw OC perpendicular to AB . Join OA and OB .

Now moment of the force P about O

$$= P \times OC = AB \times OC$$

But $AB \times OC$ is equal to twice the area of triangle ABO . Thus the moment of a force, about any point, is equal to twice the area of the triangle, whose base is the line to some scale representing the force and whose vertex is the point about which the moment is taken.

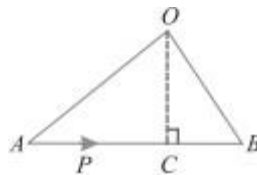

UNITS OF MOMENT:

Since the moment of a force is the product of force and distance, therefore the units of the moment will depend upon the units of force and distance. Thus, if the force is in Newton and the distance is in meters, then the units of moment will be Newton-meter (briefly written as N-m). Similarly, the units of moment may be kN-m (*i.e.* kN \times m), N-mm (*i.e.* N \times mm) etc.

TYPES OF MOMENTS:

Broadly speaking, the moments are of the following two types:

1. Clockwise moments.
2. Anticlockwise moments.

CLOCKWISE MOMENT:

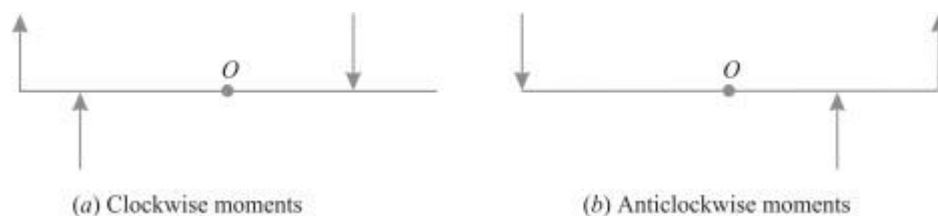

It is the moment of a force, whose effect is to turn or rotate the body, about the point in the same direction in which hands of a clock move as shown in Fig.

ANTICLOCKWISE MOMENT:

It is the moment of a force, whose effect is to turn or rotate the body, about the point in the opposite direction in which the hands of a clock move as shown in Fig.(b).

Note. The general convention is to take clockwise moment as positive and anticlockwise moment as negative.

VARIGNON’S PRINCIPLE OR LAW OF MOMENTS:

It states, “If a number of coplanar forces are acting simultaneously on a particle, the algebraic sum of the moments of all the forces about any point is equal to the moment of their resultant force about the same point.”

EXAMPLE: A uniform wheel of 600 mm diameter, weighing 5 kN rests against a rigid rectangular block of 150 mm height as shown in Fig.

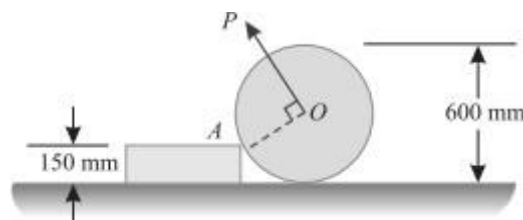

Find the least pull, through the centre of the wheel, required just to turn the wheel over the corner A of the block. Also find the reaction on the block. Take all the surfaces to be smooth.

Solution. Given : Diameter of wheel = 600 mm; Weight of wheel = 5 kN and height of the block = 150 mm.

Least pull required just to turn the wheel over the corner.

Let P = Least pull required just to turn the wheel in kN.

A little consideration will show that for the least pull, it must be applied normal to AO . The system of forces is shown in Fig. 3.9. From the geometry of the figure, we find that

$$\sin \theta = \frac{150}{300} = 0.5 \quad \text{or} \quad \theta = 30^\circ$$

and

$$AB = \sqrt{(300)^2 - (150)^2} = 260 \text{ mm}$$

Now taking moments about A and equating the same,

$$P \times 300 = 5 \times 260 = 1300$$

$$\therefore P = \frac{1300}{300} = 4.33 \text{ kN} \quad \text{Ans.}$$

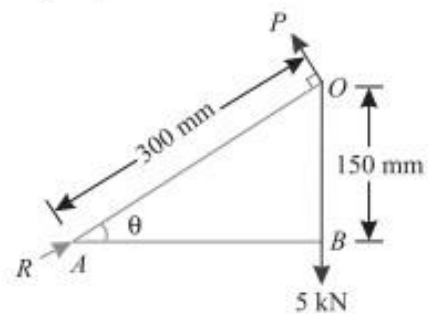

Reaction on the block

Let R = Reaction on the block in kN.

Resolving the forces horizontally and equating the same,

$$R \cos 30^\circ = P \sin 30^\circ$$

$$\therefore R = \frac{P \sin 30^\circ}{\cos 30^\circ} = \frac{4.33 \times 0.5}{0.866} = 2.5 \text{ kN} \quad \text{Ans.}$$

EXAMPLE: Four forces equal to P , $2P$, $3P$ and $4P$ are respectively acting along the four sides of square $ABCD$ taken in order. Find the magnitude, direction and position of the resultant force.

Solution. The system of given forces is shown in Fig. 3.12.

Magnitude of the resultant force

Resolving all the forces horizontally,

$$\sum H = P - 3P = -2P \quad \dots(i)$$

and now resolving all forces vertically,

$$\sum V = 2P - 4P = -2P \quad \dots(ii)$$

We know that magnitude of the resultant forces,

$$R = \sqrt{(\sum H)^2 + (\sum V)^2} = \sqrt{(-2P)^2 + (-2P)^2}$$

$$= 2\sqrt{2}P \quad \text{Ans.}$$

Direction of the resultant force

Let θ = Angle, which the resultant makes with the horizontal.

$$\therefore \tan \theta = \frac{\sum V}{\sum H} = \frac{-2P}{-2P} = 1 \quad \text{or } \theta = 45^\circ$$

Since $\sum H$ as well as $\sum V$ are $-ve$, therefore resultant lies between 180° and 270° . Thus actual angle of the resultant force = $180^\circ + 45^\circ = 225^\circ$ **Ans.**

Position of the resultant force

Let x = Perpendicular distance between A and the line of action of the resultant force.

Now taking moments of the resultant force about A and equating the same,

$$2\sqrt{2}P \times x = (2P \times a) + (3P \times a) = 5P \times a$$

$$\therefore x = \frac{5a}{2\sqrt{2}} \quad \text{Ans.}$$

Note. The moment of the forces P and $4P$ about the point A will be zero, as they pass through it.

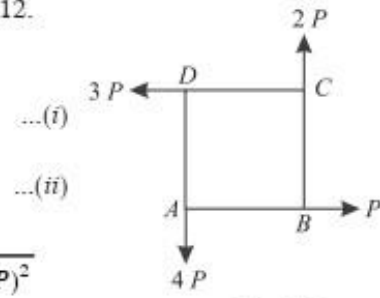

COUPLE: A pair of two equal and unlike parallel forces (*i.e.* forces equal in magnitude, with lines of action parallel to each other and acting in opposite directions) is known as a couple.

As a matter of fact, a couple is unable to produce any translatory motion (*i.e.*, motion in a straight line). But it produces a motion of rotation in the body, on which it acts. The simplest example of a couple is the forces applied to the key of a lock, while locking or unlocking it.

ARM OF A COUPLE:

The perpendicular distance (a), between the lines of action of the two equal and opposite parallel forces, is known as *arm of the couple* as shown in Fig.

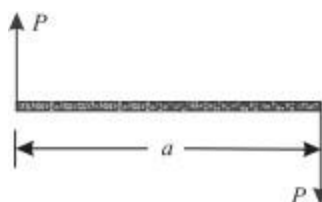

MOMENT OF A COUPLE: The moment of a couple is the product of the force (*i.e.*, one of the forces of the two equal and opposite parallel forces) and the arm of the couple.

Mathematically:

$$\text{Moment of a couple} = P \times a$$

where P = Magnitude of the force, and
 a = Arm of the couple.

CLASSIFICATION OF COUPLES:

The couples may be, broadly, classified into the following two categories, depending upon their direction, in which the couple tends to rotate the body, on which it acts:

1. Clockwise couple, and
2. Anticlockwise couple

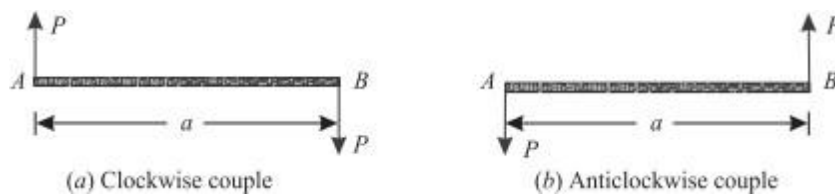

CLOCKWISE COUPLE:

A couple, whose tendency is to rotate the body, on which it acts, in a clockwise direction, is known as a clockwise couple as shown in Fig. (a). Such a couple is also called positive couple.

ANTICLOCKWISE COUPLE:

A couple, whose tendency is to rotate the body, on which it acts, in an anticlockwise direction, is known as an anticlockwise couple as shown in Fig. (b). Such a couple is also called a negative couple.

CHARACTERISTICS OF A COUPLE:

A couple (whether clockwise or anticlockwise) has the following characteristics:

1. The algebraic sum of the forces, constituting the couple, is zero.
2. The algebraic sum of the moments of the forces, constituting the couple, about any point is the same, and equal to the moment of the couple itself.
3. A couple cannot be balanced by a single force. But it can be balanced only by a couple of opposite sense.
4. Any no. of co-planer couples can be reduced to a single couple, whose magnitude will be equal to the algebraic sum of the moments of all the couples.

EXAMPLE: A square ABCD has forces acting along its sides as shown in Fig. 4.13. Find the values of P and Q , if the system reduces to a couple. Also find magnitude of the couple, if the side of the square is 1 m.

Solution. Given : Length of square = 1 m

Values of P and Q

We know that if the system reduces to a couple, the resultant force in horizontal and vertical directions must be zero. Resolving the forces horizontally,

$$100 - 100 \cos 45^\circ - P = 0$$

$$\begin{aligned} \therefore P &= 100 - 100 \cos 45^\circ \text{ N} \\ &= 100 - (100 \times 0.707) = 29.3 \text{ N } \mathbf{Ans.} \end{aligned}$$

Now resolving the forces vertically,

$$200 - 100 \sin 45^\circ - Q = 0$$

$$\therefore Q = 200 - (100 \times 0.707) = 129.3 \text{ N } \mathbf{Ans.}$$

Magnitude of the couple

We know that moment of the couple is equal to the algebraic sum of the moments about any point. Therefore moment of the couple (taking moments about A)

$$\begin{aligned} &= (-200 \times 1) + (-P \times 1) = -200 - (29.3 \times 1) \text{ N-m} \\ &= -229.3 \text{ N-m } \mathbf{Ans.} \end{aligned}$$

Since the value of moment is negative, therefore the couple is anticlockwise.

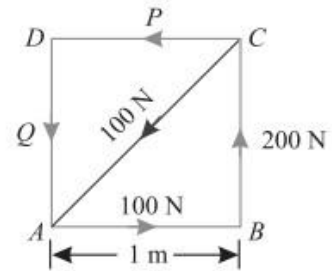

FRICTION

INTRODUCTION:

If a block of one substance is placed over the level surface of the same or different material, a certain degree of interlocking of the minutely projecting particles takes place. This does not involve any force, so long as the block does not move or tends to move. But whenever one of the blocks moves or tends to move tangentially with respect to the surface, on which it rests, the interlocking property of the projecting particles opposes the motion. This opposing force, which acts in the opposite direction of the movement of the block, is called *force of friction* or simply *friction*. It is of the following two types:

1. Static friction.
2. Dynamic friction

STATIC FRICTION:

It is the friction experienced by a body when it is at rest. Or in other words, it is the friction when the body tends to move.

DYNAMIC FRICTION:

It is the friction experienced by a body when it is in motion. It is also called kinetic friction. The dynamic friction is of the following two types:

1. **Sliding friction:** It is the friction, experienced by a body when it slides over another body.
2. **Rolling friction:** It is the friction, experienced by a body when it rolls over another body.

LIMITING FRICTION: The maximum value of frictional force, which comes into play, when a body just begins to slide over the surface of the other body, is known as limiting friction. It may be noted that when the applied force is less than the limiting friction, the body remains at rest, and the friction is called static friction, which may have any value between zero and limiting friction.

COEFFICIENT OF FRICTION:

It is the ratio of limiting friction to the normal reaction, between the two bodies, and is generally denoted by μ .

Mathematically, coefficient of friction,

$$\mu = \frac{F}{R} = \tan \phi \quad \text{or} \quad F = \mu R$$

ϕ = Angle of friction,

F = Limiting friction, and

R = Normal reaction between the two bodies.

ANGLE OF FRICTION: Consider a body of weight W resting on an inclined plane as shown in Fig. We know that the body is in equilibrium under the action of the following forces:

1. Weight (W) of the body, acting vertically downwards,
2. Friction force (F) acting upwards along the plane, and
3. Normal reaction (R) acting at right angles to the plane.

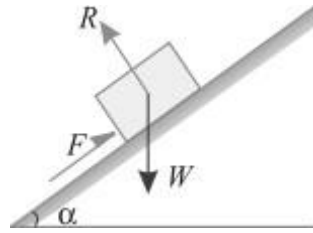

Let the angle of inclination (α) be gradually increased, till the body just starts sliding down the plane. This angle of inclined plane, at which a body just begins to slide down the plane, is called the angle of friction. This is also equal to the angle, which the normal reaction makes with the vertical.

ANGLE OF REPOSE: Angle of repose is defined as the angle of the inclined plane with horizontal such that a body placed on it just begins to slide.

LAWS OF FRICTION:

Prof. Coulomb, after extensive experiments, gave some laws of friction, which may be grouped under the following heads :

1. Laws of static friction, and
2. Laws of kinetic or dynamic friction

LAWS OF STATIC FRICTION:

Following are the laws of static friction :

1. The force of friction always acts in a direction, opposite to that in which the body tends to move, if the force of friction would have been absent.
2. The magnitude of the force of friction is exactly equal to the force, which tends to move the body.
3. The magnitude of the limiting friction bears a constant ratio to the normal reaction between the two surfaces. Mathematically:

$$F/R = \text{CONSTANT}$$

4. The force of friction is independent of the area of contact between the two surfaces.
5. The force of friction depends upon the roughness of the surfaces

LAWS OF KINETIC OR DYNAMIC FRICTION:

Following are the laws of kinetic or dynamic friction:

1. The force of friction always acts in a direction, opposite to that in which the body is moving.
2. The magnitude of kinetic friction bears a constant ratio to the normal reaction between the two surfaces. But this ratio is slightly less than that in case of limiting friction.
3. For moderate speeds, the force of friction remains constant. But it decreases slightly with the increase of speed.

ADVANTAGES OF FRICTION:

- Friction is responsible for many types of motion
- It helps us walk on the ground
- Brakes in a car make use of friction to stop the car

- Asteroids are burnt in the atmosphere before reaching Earth due to friction.
- It helps in the generation of heat when we rub our hands.

DISADVANTAGES OF FRICTION:

- Friction produces unnecessary heat leading to the wastage of energy.
- The force of friction acts in the opposite direction of motion, so friction slows down the motion of moving objects.
- A lot of money goes into preventing friction and the usual wear and tear caused by it by using techniques like greasing and oiling.

EQUILIBRIUM OF A BODY ON A ROUGH HORIZONTAL PLANE:

We know that a body, lying on a rough horizontal plane will remain in equilibrium. But whenever a force is applied on it, the body will tend to move in the direction of the force. In such cases, equilibrium of the body is studied first by resolving the forces horizontally and then vertically.

Now the value of the force of friction is obtained from the relation:

$$F = \mu R$$

EXAMPLE: A body of weight 300 N is lying on a rough horizontal plane having a coefficient of friction as 0.3. Find the magnitude of the force, which can move the body, while acting at an angle of 25° with the horizontal.

Solution. Given: Weight of the body (W) = 300 N; Coefficient of friction (μ) = 0.3 and angle made by the force with the horizontal (α) = 25°

Let P = Magnitude of the force, which can move the body, and

F = Force of friction.

Resolving the forces horizontally,

$$F = P \cos \alpha = P \cos 25^\circ = P \times 0.9063$$

and now resolving the forces vertically,

$$\begin{aligned} R &= W - P \sin \alpha = 300 - P \sin 25^\circ \\ &= 300 - P \times 0.4226 \end{aligned}$$

We know that the force of friction (F),

$$0.9063 P = \mu R = 0.3 \times (300 - 0.4226 P) = 90 - 0.1268 P$$

or $90 = 0.9063 P + 0.1268 P = 1.0331 P$

$\therefore P = \frac{90}{1.0331} = 87.1 \text{ N}$ **Ans.**

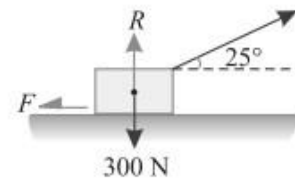

EQUILIBRIUM OF A BODY ON A ROUGH INCLINED PLANE:

Consider a body, of weight W , lying on a rough plane inclined at an angle α with the horizontal as shown in Fig.(a) and (b).

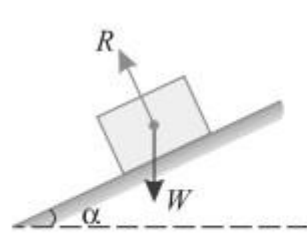

(a) Angle of inclination less than the angle of friction

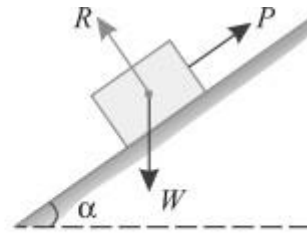

(b) Angle of inclination more than the angle of friction

A little consideration will show, that if the inclination of the plane, with the horizontal, is less the angle of friction, the body will be automatically in equilibrium as shown in Fig. (a). If in this condition, the body is required to be moved upwards or downwards, a corresponding force is required, for the same. But, if the inclination of the plane is more than the angle of friction, the body will move down. And an upward force (P) will be required to resist the body from moving down the plane as shown in Fig. (b).

Though there are many types of forces, for the movement of the body, yet the following are important from the subject point of view :

1. Force acting along the inclined plane.
2. Force acting horizontally.
3. Force acting at some angle with the inclined plane.

EQUILIBRIUM OF A BODY ON A ROUGH INCLINED PLANE SUBJECTED TO A FORCE ACTING ALONG THE INCLINED PLANE:

Consider a body lying on a rough inclined plane subjected force acting along the inclined plane, which keeps it in equilibrium as shown in Fig.(a) and (b).

Let W = Weight of the body,

α = Angle, which the inclined plane makes with the horizontal,

R = Normal reaction,

μ = Coefficient of friction between the body and the inclined plane, and

ϕ = Angle of friction, such that $\mu = \tan \phi$.

A little consideration will show that if the force is not there, the body will slide down the plane. Now we shall discuss the following two cases:

1. Minimum force (P_1) which will keep the body in equilibrium, when it is at the point of sliding downwards:

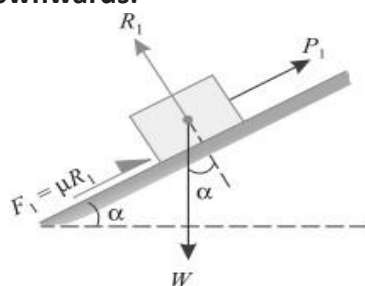

(a) Body at the point of sliding downwards

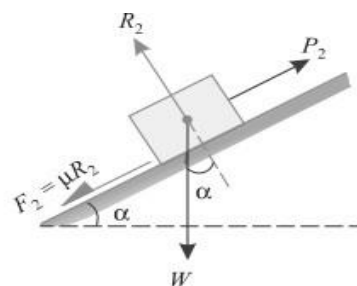

(b) Body at the point of sliding upwards

In this case, the force of friction ($F_1 = \mu.R_1$) will act upwards, as the body is at the point of sliding downwards as shown in Fig. 8.8 (a). Now resolving the forces along the plane,

$$P_1 = W \sin \alpha - \mu.R_1 \quad \dots(i)$$

and now resolving the forces perpendicular to the plane.

$$R_1 = W \cos \alpha \quad \dots(ii)$$

Substituting the value of R_1 in equation (i),

$$P_1 = W \sin \alpha - \mu W \cos \alpha = W (\sin \alpha - \mu \cos \alpha)$$

and now substituting the value of $\mu = \tan \phi$ in the above equation,

$$P_1 = W (\sin \alpha - \tan \phi \cos \alpha)$$

Multiplying both sides of this equation by $\cos \phi$,

$$P_1 \cos \phi = W (\sin \alpha \cos \phi - \sin \phi \cos \alpha) = W \sin (\alpha - \phi)$$

$$\therefore P_1 = W \times \frac{\sin (\alpha - \phi)}{\cos \phi}$$

2. *Maximum force (P_2) which will keep the body in equilibrium, when it is at the point of sliding upwards.*

In this case, the force of friction ($F_2 = \mu.R_2$) will act downwards as the body is at the point of sliding upwards as shown in Fig. 8.8 (b). Now resolving the forces along the plane,

$$P_2 = W \sin \alpha + \mu.R_2 \quad \dots(i)$$

and now resolving the forces perpendicular to the plane,

$$R_2 = W \cos \alpha \quad \dots(ii)$$

Substituting the value of R_2 in equation (i),

$$P_2 = W \sin \alpha + \mu W \cos \alpha = W (\sin \alpha + \mu \cos \alpha)$$

and now substituting the value of $\mu = \tan \phi$ in the above equation,

$$P_2 = W (\sin \alpha + \tan \phi \cos \alpha)$$

Multiplying both sides of this equation by $\cos \phi$,

$$P_2 \cos \phi = W (\sin \alpha \cos \phi + \sin \phi \cos \alpha) = W \sin (\alpha + \phi)$$

$$\therefore P_2 = W \times \frac{\sin (\alpha + \phi)}{\cos \phi}$$

EXAMPLE: A body of weight 500 N is lying on a rough plane inclined at an angle of 25° with the horizontal. It is supported by an effort (P) parallel to the plane as shown in Fig. Determine the minimum and maximum values of P , for which the equilibrium can exist, if the angle of friction is 20° .

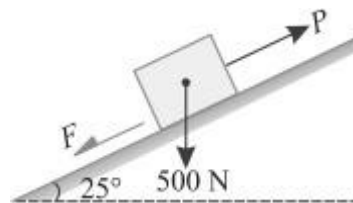

Solution. Given: Weight of the body (W) = 500 N ; Angle at which plane is inclined (α) = 25° and angle of friction (ϕ) = 20° .

Minimum value of P

We know that for the minimum value of P , the body is at the point of sliding downwards. We also know that when the body is at the point of sliding downwards, then the force

$$\begin{aligned} P_1 &= W \times \frac{\sin (\alpha - \phi)}{\cos \phi} = 500 \times \frac{\sin (25^\circ - 20^\circ)}{\cos 20^\circ} \text{ N} \\ &= 500 \times \frac{\sin 5^\circ}{\cos 20^\circ} = 500 \times \frac{0.0872}{0.9397} = 46.4 \text{ N} \quad \text{Ans.} \end{aligned}$$

Maximum value of P

We know that for the maximum value of P , the body is at the point of sliding upwards. We also know that when the body is at the point of sliding upwards, then the force

$$\begin{aligned} P_2 &= W \times \frac{\sin (\alpha + \phi)}{\cos \phi} = 500 \times \frac{\sin (25^\circ + 20^\circ)}{\cos 20^\circ} \text{ N} \\ &= 500 \times \frac{\sin 45^\circ}{\cos 20^\circ} = 500 \times \frac{0.7071}{0.9397} = 376.2 \text{ N} \quad \text{Ans.} \end{aligned}$$

EQUILIBRIUM OF A BODY ON A ROUGH INCLINED PLANE SUBJECTED TO A FORCE ACTING HORIZONTALLY:

Consider a body lying on a rough inclined plane subjected to a force acting horizontally, which keeps it in equilibrium as shown in Fig.(a) and (b).

W = Weight of the body,

α = Angle, which the inclined plane makes with the horizontal,

R = Normal reaction,

μ = Coefficient of friction between the body and the inclined plane, and

ϕ = Angle of friction, such that $\mu = \tan \phi$.

A little consideration will show that if the force is not there, the body will slide down on the plane.

Now we shall discuss the following two cases:

1. Minimum force (P_1) which will keep the body in equilibrium, when it is at the point of sliding downwards.

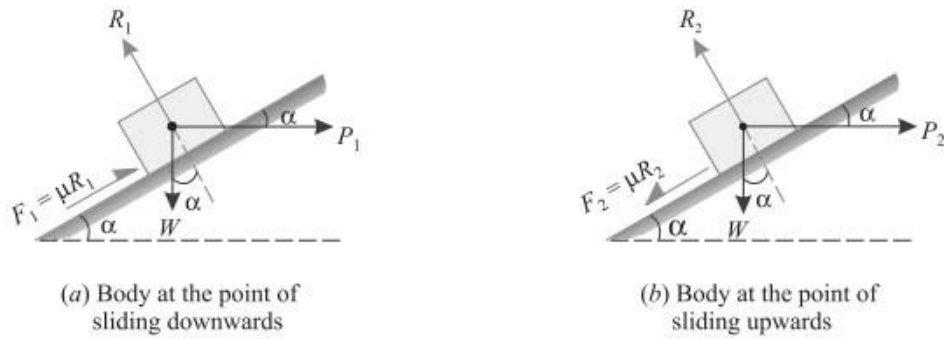

Fig. 8.13.

In this case, the force of friction ($F_1 = \mu R_1$) will act upwards, as the body is at the point of sliding downwards as shown in Fig. 8.13. (a). Now resolving the forces along the plane,

$$P_1 \cos \alpha = W \sin \alpha - \mu R_1 \quad \dots(i)$$

and now resolving the forces perpendicular to the plane,

$$R_1 = W \cos \alpha + P_1 \sin \alpha \quad \dots(ii)$$

Substituting this value of R_1 in equation (i),

$$\begin{aligned} P_1 \cos \alpha &= W \sin \alpha - \mu(W \cos \alpha + P_1 \sin \alpha) \\ &= W \sin \alpha - \mu W \cos \alpha - \mu P_1 \sin \alpha \end{aligned}$$

$$P_1 \cos \alpha + \mu P_1 \sin \alpha = W \sin \alpha - \mu W \cos \alpha$$

$$P_1(\cos \alpha + \mu \sin \alpha) = W(\sin \alpha - \mu \cos \alpha)$$

$$\therefore P_1 = W \times \frac{(\sin \alpha - \mu \cos \alpha)}{(\cos \alpha + \mu \sin \alpha)}$$

Now substituting the value of $\mu = \tan \phi$ in the above equation,

$$P_1 = W \times \frac{(\sin \alpha - \tan \phi \cos \alpha)}{(\cos \alpha + \tan \phi \sin \alpha)}$$

Multiplying the numerator and denominator by $\cos \phi$,

$$\begin{aligned} P_1 &= W \times \frac{\sin \alpha \cos \phi - \sin \phi \cos \alpha}{\cos \alpha \cos \phi + \sin \alpha \sin \phi} = W \times \frac{\sin(\alpha - \phi)}{\cos(\alpha - \phi)} \\ &= W \tan(\alpha - \phi) \quad \dots(\text{when } \alpha > \phi) \\ &= W \tan(\phi - \alpha) \quad \dots(\text{when } \phi > \alpha) \end{aligned}$$

2. Maximum force (P_2) which will keep the body in equilibrium, when it is at the point of sliding upwards

In this case, the force of friction ($F_2 = \mu R_2$) will act downwards, as the body is at the point of sliding upwards as shown in Fig.8.12. (b). Now resolving the forces along the plane,

$$P_2 \cos \alpha = W \sin \alpha + \mu R_2 \quad \dots(iii)$$

and now resolving the forces perpendicular to the plane,

$$R_2 = W \cos \alpha + P_2 \sin \alpha \quad \dots(iv)$$

Substituting this value of R_2 in the equation (iii),

$$\begin{aligned} P_2 \cos \alpha &= W \sin \alpha + \mu (W \cos \alpha + P_2 \sin \alpha) \\ &= W \sin \alpha + \mu W \cos \alpha + \mu P_2 \sin \alpha \end{aligned}$$

$$P_2 \cos \alpha - \mu P_2 \sin \alpha = W \sin \alpha + \mu W \cos \alpha$$

$$P_2 (\cos \alpha - \mu \sin \alpha) = W (\sin \alpha + \mu \cos \alpha)$$

$$\therefore P_2 = W \times \frac{(\sin \alpha + \mu \cos \alpha)}{(\cos \alpha - \mu \sin \alpha)}$$

Now substituting the value of $\mu = \tan \phi$ in the above equation,

$$P_2 = W \times \frac{\sin \alpha + \tan \phi \cos \alpha}{\cos \alpha - \tan \phi \sin \alpha}$$

Multiplying the numerator and denominator by $\cos \phi$,

$$\begin{aligned} P_2 &= W \times \frac{\sin \alpha \cos \phi + \sin \phi \cos \alpha}{\cos \alpha \cos \phi - \sin \phi \sin \alpha} = W \times \frac{\sin (\alpha + \phi)}{\cos (\alpha + \phi)} \\ &= W \tan (\alpha + \phi) \end{aligned}$$

EXAMPLE: A load of 1.5 kN, resting on an inclined rough plane, can be moved up the plane by a force of 2 kN applied horizontally or by a force 1.25 kN applied parallel to the plane. Find the inclination of the plane and the coefficient of friction.

Solution. Given: Load (W) = 1.5 kN; Horizontal effort (P_1) = 2 kN and effort parallel to the inclined plane (P_2) = 1.25 kN.

Inclination of the plane

Let α = Inclination of the plane, and
 ϕ = Angle of friction.

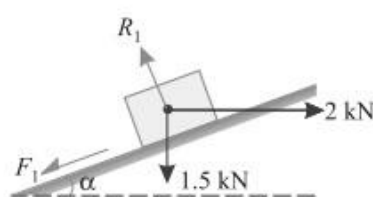

(a) Horizontal force

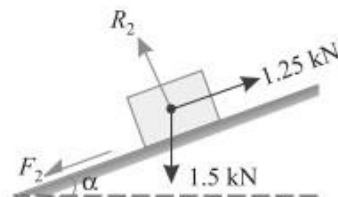

(b) Force parallel to the plane

First of all, consider the load of 1.5 kN subjected to a horizontal force of 2 kN as shown in Fig. 8.14 (a). We know that when the force is applied horizontally, then the magnitude of the force, which can move the load up the plane.

$$P = W \tan (\alpha + \phi)$$

or $2 = 1.5 \tan (\alpha + \phi)$

$$\therefore \tan (\alpha + \phi) = \frac{2}{1.5} = 1.333 \quad \text{or} \quad (\alpha + \phi) = 53.1^\circ$$

Now consider the load of 1.5 kN subjected to a force of 1.25 kN along the plane as shown in Fig. 8.14 (b). We know that when the force is applied parallel to the plane, then the magnitude of the force, which can move the load up the plane,

$$P = W \times \frac{\sin (\alpha + \phi)}{\cos \phi}$$

or $1.25 = 1.5 \times \frac{\sin 53.1^\circ}{\cos \phi} = 1.5 \times \frac{0.8}{\cos \phi} = \frac{1.2}{\cos \phi}$

$$\therefore \cos \phi = \frac{1.2}{1.25} = 0.96 \quad \text{or} \quad \phi = 16.3^\circ$$

and $\alpha = 53.1^\circ - 16.3^\circ = 36.8^\circ$ **Ans.**

Coefficient of friction

We know that the coefficient of friction,

$$\mu = \tan \phi = \tan 16.3^\circ = 0.292 \quad \text{Ans.}$$

EQUILIBRIUM OF A BODY ON A ROUGH INCLINED PLANE SUBJECTED TO A FORCE ACTING AT SOME ANGLE WITH THE INCLINED PLANE:

Consider a body lying on a rough inclined plane subjected to a force acting at some angle with the inclined plane, which keeps it in equilibrium as shown in Fig.(a) and (b).

Let W = Weight of the body,

α = Angle which the inclined plane makes with the horizontal,

θ = Angle which the force makes with the inclined surface,

R = Normal reaction,

μ = Coefficient of friction between the body and the inclined plane, and

ϕ = Angle of friction, such that $\mu = \tan \phi$.

A little consideration will show that if the force is not there, the body will slide down the plane.

Now we shall discuss the following two cases :

1. Minimum force (P_1) which will keep the body in equilibrium when it is at the point of sliding downwards.

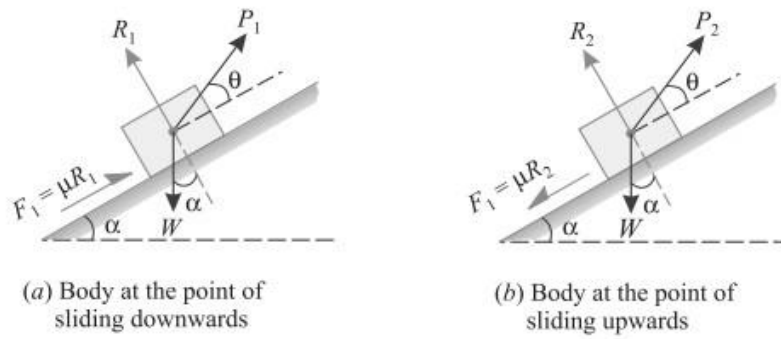

Fig. 8.17.

In this case, the force of friction ($F_1 = \mu R_1$) will act upwards, as the body is at the point of sliding downwards as shown in Fig. 8.17 (a). Now resolving the forces along the plane,

$$P_1 \cos \theta = W \sin \alpha - \mu R_1 \quad \dots(i)$$

and now resolving the forces perpendicular to the plane,

$$R_1 = W \cos \alpha - P_1 \sin \theta \quad \dots(ii)$$

Substituting the value of R_1 in equation (i),

$$\begin{aligned} P_1 \cos \theta &= W \sin \alpha - \mu (W \cos \alpha - P_1 \sin \theta) \\ &= W \sin \alpha - \mu W \cos \alpha + \mu P_1 \sin \theta \end{aligned}$$

$$P_1 \cos \theta - \mu P_1 \sin \theta = W \sin \alpha - \mu W \cos \alpha$$

$$P_1 (\cos \theta - \mu \sin \theta) = W (\sin \alpha - \mu \cos \alpha)$$

$$\therefore P_1 = W \times \frac{(\sin \alpha - \mu \cos \alpha)}{(\cos \theta - \mu \sin \theta)}$$

and now substituting the value of $\mu = \tan \phi$ in the above equation,

$$P_1 = W \times \frac{(\sin \alpha - \tan \phi \cos \alpha)}{(\cos \theta - \tan \phi \sin \theta)}$$

Multiplying the numerator and denominator by $\cos \phi$,

$$P_1 = W \times \frac{(\sin \alpha \cos \phi - \sin \phi \cos \alpha)}{(\cos \theta \cos \phi - \sin \phi \sin \theta)} = W \times \frac{\sin (\alpha - \phi)}{\cos (\theta + \phi)}$$

2. Maximum force (P_2) which will keep the body in equilibrium, when it is at the point of sliding upwards.

In this case, the force of friction ($F_2 = \mu R_2$) will act downwards as the body is at the point of sliding upwards as shown in Fig. 8.17 (b). Now resolving the forces along the plane.

$$P_2 \cos \theta = W \sin \alpha + \mu R_2 \quad \dots(iii)$$

and now resolving the forces perpendicular to the plane,

$$R_2 = W \cos \alpha - P_2 \sin \theta \quad \dots(iv)$$

Substituting the value of R_2 in equation (iii),

$$\begin{aligned} P_2 \cos \theta &= W \sin \alpha + \mu (W \cos \alpha - P_2 \sin \theta) \\ &= W \sin \alpha + \mu W \cos \alpha - \mu P_2 \sin \theta \end{aligned}$$

$$P_2 \cos \theta + \mu P_2 \sin \theta = W \sin \alpha + \mu W \cos \alpha$$

$$P_2 (\cos \theta + \mu \sin \theta) = W (\sin \alpha + \mu \cos \alpha)$$

$$\therefore P_2 = W \times \frac{(\sin \alpha + \mu \cos \alpha)}{(\cos \theta + \mu \sin \theta)}$$

and now substituting the value of $\mu = \tan \phi$ in the above equation,

$$P_2 = W \times \frac{(\sin \alpha + \tan \phi \cos \alpha)}{(\cos \theta + \tan \phi \sin \theta)}$$

Multiplying the numerator and denominator by $\cos \phi$,

$$P_2 = W \times \frac{(\sin \alpha \cos \phi + \sin \phi \cos \alpha)}{(\cos \theta \cos \phi + \sin \phi \sin \theta)} = W \times \frac{\sin (\alpha + \phi)}{\cos (\theta - \phi)}$$

EXAMPLE: Find the force required to move a load of 300 N up a rough plane, the force being applied parallel to the plane. The inclination of the plane is such that when the same load is kept on a perfectly smooth plane inclined at the same angle, a force of 60 N applied at an inclination of 30° to the plane, keeps the same load in equilibrium. Assume coefficient of friction between the rough plane and the load to be equal to 0.3.

Solution. Given: Load (W) = 300 N; Force (P_1) = 60 N and angle at which force is inclined (θ) = 30° ,

Let α = Angle of inclination of the plane.

First of all, consider the load lying on a smooth plane inclined at an angle (α) with the horizontal and subjected to a force of 60 N acting at an angle 30° with the plane as shown in Fig. 8.18 (a).

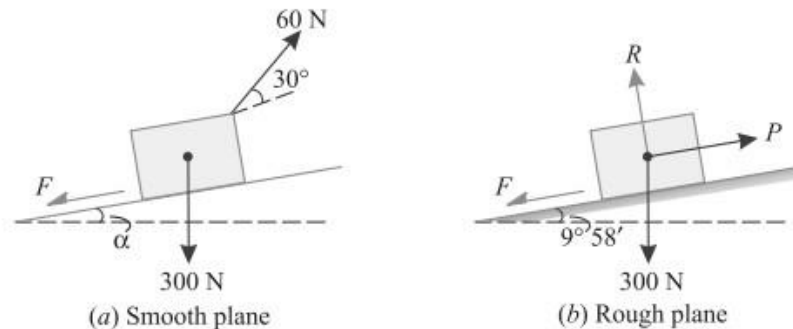

We know that in this case, because of the smooth plane $\mu = 0$ or $\phi = 0$. We also know that the force required, when the load is at the point of sliding upwards (P),

$$60 = W \times \frac{\sin(\alpha + \phi)}{\cos(\theta - \phi)} = 300 \times \frac{\sin \alpha}{\cos 30^\circ} = 300 \times \frac{\sin \alpha}{0.866} = 346.4 \sin \alpha$$

...($\because \phi = 0$)

or $\sin \alpha = \frac{60}{346.4} = 0.1732$ or $\alpha = 10^\circ$

Now consider the load lying on the rough plane inclined at an angle of 10° with the horizontal as shown in Fig. 8.18. (b). We know that in this case, $\mu = 0.3 = \tan \phi$ or $\phi = 16.7^\circ$.

We also know that force required to move the load up the plane,

$$\begin{aligned} P &= W \times \frac{\sin(\alpha + \phi)}{\cos \phi} = 300 \times \frac{\sin(10^\circ + 16.7^\circ)}{\cos 16.7^\circ} \text{ N} \\ &= 300 \times \frac{\sin 26.7^\circ}{\cos 16.7^\circ} = 300 \times \frac{0.4493}{0.9578} = 140.7 \text{ N} \quad \text{Ans.} \end{aligned}$$

UNIT - 2

EQUILIBRIUM OF SYSTEM OF FORCES

EQUILIBRIUM:

If the resultant of a number of forces, acting on a particle is zero, the particle will be in equilibrium. Such a set of forces, whose resultant is zero, are called equilibrium forces. The force, which brings the set of forces in equilibrium is called an equilibrant.

PRINCIPLES OF EQUILIBRIUM:

Though there are many principles of equilibrium, yet the following three are important from the subject point of view :

1. Two force principle:

As per this principle, if a body in equilibrium is acted upon by two forces, then they must be equal, opposite and collinear.

2. Three force principle:

As per this principle, if a body in equilibrium is acted upon by three forces, then the resultant of any two forces must be equal, opposite and collinear with the third force.

3. Four force principle:

As per this principle, if a body in equilibrium is acted upon by four forces, then the resultant of any two forces must be equal, opposite and collinear with the resultant of the other two forces.

METHODS FOR THE EQUILIBRIUM OF COPLANAR FORCES:

Though there are many methods of studying the equilibrium of forces, yet the following are important from the subject point of view :

1. Analytical method. 2. Graphical method.

LAMI'S THEOREM:

It states, "If three coplanar forces acting at a point be in equilibrium, then each force is proportional to the sine of the angle between the other two."

Mathematically,

$$\frac{P}{\sin \alpha} = \frac{Q}{\sin \beta} = \frac{R}{\sin \gamma}$$

Proof

Consider three coplanar forces P , Q , and R acting at a point O . Let the opposite angles to three forces be α , β and γ as shown in Fig. 5.2.

Now let us complete the parallelogram $OACB$ with OA and OB as adjacent sides as shown in the figure. We know that the resultant of two forces P and Q will be given by the diagonal OC both in magnitude and direction of the parallelogram $OACB$.

Since these forces are in equilibrium, therefore the resultant of the forces P and Q must be in line with OD and equal to R , but in opposite direction.

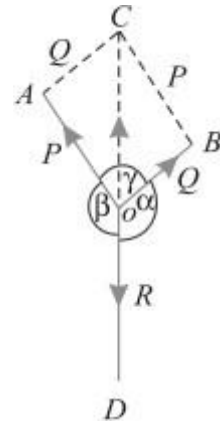

From the geometry of the figure, we find

$$BC = P \text{ and } AC = Q$$

$$\therefore \angle AOC = (180^\circ - \beta)$$

and $\angle ACO = \angle BOC = (180^\circ - \alpha)$

$$\begin{aligned} \therefore \angle CAO &= 180^\circ - (\angle AOC + \angle ACO) \\ &= 180^\circ - [(180^\circ - \beta) + (180^\circ - \alpha)] \\ &= 180^\circ - 180^\circ + \beta - 180^\circ + \alpha \\ &= \alpha + \beta - 180^\circ \end{aligned}$$

But $\alpha + \beta + \gamma = 360^\circ$

Subtracting 180° from both sides of the above equation,

$$(\alpha + \beta - 180^\circ) + \gamma = 360^\circ - 180^\circ = 180^\circ$$

or $\angle CAO = 180^\circ - \gamma$

We know that in triangle AOC ,

$$\frac{OA}{\sin \angle ACO} = \frac{AC}{\sin \angle AOC} = \frac{OC}{\sin \angle CAO}$$

$$\frac{OA}{\sin (180^\circ - \alpha)} = \frac{AC}{\sin (180^\circ - \beta)} = \frac{OC}{\sin (180^\circ - \gamma)}$$

or $\frac{P}{\sin \alpha} = \frac{Q}{\sin \beta} = \frac{R}{\sin \gamma}$

EXAMPLE: An electric light fixture weighting 15 N hangs from a point C, by two strings AC and BC. The string AC is inclined at 60° to the horizontal and BC at 45° to the horizontal as shown in Fig. Using Lami's theorem, or otherwise, determine the force in the strings AC.

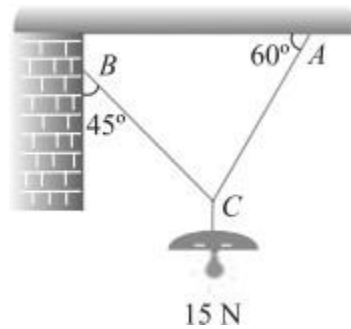

Solution. Given : Weight at C = 15 N

Let T_{AC} = Force in the string AC, and
 T_{BC} = Force in the string BC.

The system of forces is shown in Fig. 5.4. From the geometry of the figure, we find that angle between T_{AC} and 15 N is 150° and angle between T_{BC} and 15 N is 135°.

$$\therefore \angle ACB = 180^\circ - (45^\circ + 60^\circ) = 75^\circ$$

Applying Lami's equation at C,

$$\frac{15}{\sin 75^\circ} = \frac{T_{AC}}{\sin 135^\circ} = \frac{T_{BC}}{\sin 150^\circ}$$

or
$$\frac{15}{\sin 75^\circ} = \frac{T_{AC}}{\sin 45^\circ} = \frac{T_{BC}}{\sin 30^\circ}$$

$$\therefore T_{AC} = \frac{15 \sin 45^\circ}{\sin 75^\circ} = \frac{15 \times 0.707}{0.9659} = 10.98 \text{ N Ans.}$$

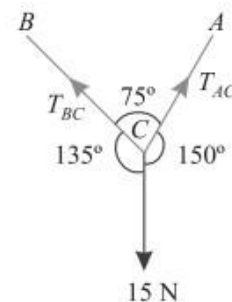

EXAMPLE: Two equal heavy spheres of 50 mm radius are in equilibrium within a smooth cup of 150 mm radius. Show that the reaction between the cup of one sphere is double than that between the two spheres.

Solution. Given : Radius of spheres = 50 mm and radius of the cup = 150 mm.

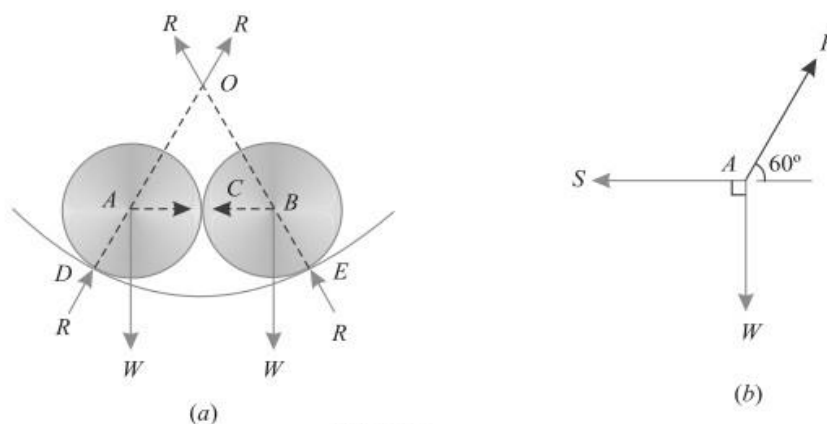

Fig. 5.11.

The two spheres with centres A and B, lying in equilibrium, in the cup with O as centre are shown in Fig. 5.11 (a). Let the two spheres touch each other at C and touch the cup at D and E respectively.

Let R = Reactions between the spheres and cup, and
 S = Reaction between the two spheres at C.

From the geometry of the figure, we find that $OD = 150$ mm and $AD = 50$ mm. Therefore $OA = 100$ mm. Similarly $OB = 100$ mm. We also find that $AB = 100$ mm. Therefore OAB is an equilateral triangle. The system of forces at A is shown in Fig. 5.11 (b).

Applying Lami's equation at A ,

$$\frac{R}{\sin 90^\circ} = \frac{W}{\sin 120^\circ} = \frac{S}{\sin 150^\circ}$$

$$\frac{R}{1} = \frac{W}{\sin 60^\circ} = \frac{S}{\sin 30^\circ}$$

$$\therefore R = \frac{S}{\sin 30^\circ} = \frac{S}{0.5} = 2S$$

Hence the reaction between the cup and the sphere is double than that between the two spheres. **Ans.**

GRAPHICAL METHOD FOR THE EQUILIBRIUM OF COPLANAR FORCES:

We have studied that the equilibrium of forces by analytical method. Sometimes, the analytical method is too tedious and complicated. The equilibrium of such forces may also be studied, graphically, by drawing the vector diagram. This may also be done by studying the

2. Converse of the Law of Triangle of Forces
3. Converse of the Law of Polygon of Forces

CONVERSE OF THE LAW OF TRIANGLE OF FORCES:

If three forces acting at a point be represented in magnitude and direction by the three sides a triangle, taken in order, the forces shall be in equilibrium.

CONVERSE OF THE LAW OF POLYGON OF FORCES:

If any number of forces acting at a point be represented in magnitude and direction by the sides of a closed polygon, taken in order, the forces shall be in equilibrium.

EXAMPLE: An electric light fixture weighing 15 N hangs from a point C , by two strings AC and BC . The string AC is inclined at 60° to the horizontal and BC at 45° to the horizontal as shown in Fig.

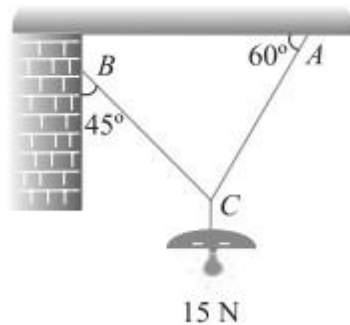

SOLUTION: Given. Weight at C = 15 N

T_{AC} = Force in the string AC, and

T_{BC} = Force in the string BC.

First of all, draw the space diagram for the joint C and name the forces according to Bow's notations as shown in Fig. The force T_{AC} is named as RQ and the force T_{BC} as PR .

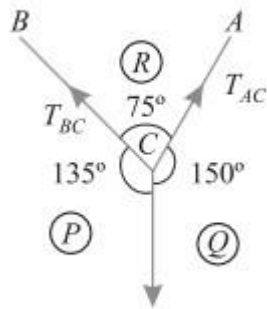

(a) Space diagram

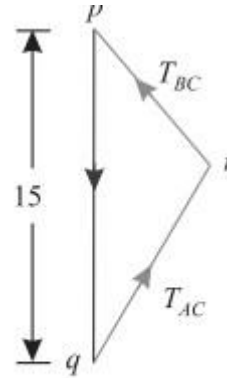

(a) Vector diagram

Now draw the vector diagram for the given system of forces as shown in Fig. (b) and as discussed below;

- Select some suitable point p and draw a vertical line pq equal to 15 N to some suitable scale representing weight (PQ) of the electric fixture.
- Through p draw a line pr parallel to PR and through q, draw a line qr parallel to QR. Let these two lines meet at r and close the triangle pqr, which means that joint C is in equilibrium.
- By measurement, we find that the forces in strings AC (T_{AC}) and BC (T_{BC}) is equal to 1.0 N and 7.8 N respectively.

CONDITIONS OF EQUILIBRIUM: If the body is completely at rest, it necessarily means that there is neither a resultant force nor a couple acting on it. A little consideration will show, that in this case the following conditions are already satisfied:

$$\sum H = 0 \quad \sum V = 0 \quad \text{and} \quad \sum M = 0$$

The above mentioned three equations are known as the conditions of equilibrium.

TYPES OF EQUILIBRIUM:

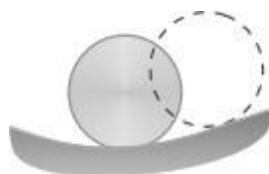

(a) Stable



(b) Unstable

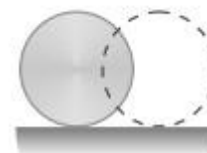

(c) Neutral

- 1. STABLE EQUILIBRIUM:** A body is said to be in stable equilibrium, if it returns back to its original position, after it is slightly displaced from its position of rest. This happens when some additional force sets up due to displacement and brings the body back to its original position. A smooth cylinder, lying in a curved surface, is in stable equilibrium. If we slightly displace the cylinder from its position of rest (as shown by dotted lines), it will tend to return back to its original position in order to bring its weight normal to horizontal axis as shown in Fig. (a).
- 2. UNSTABLE EQUILIBRIUM:** A body is said to be in an unstable equilibrium, if it does not return back to its original position, and heels farther away, after slightly displaced from its position of rest. This happens when the additional force moves the body away from its position of rest. This happens when the additional force moves the body away from its position of rest. A smooth cylinder lying on a convex surface is in unstable equilibrium. If we slightly displace the cylinder from its position of rest (as shown by dotted lines) the body will tend to move away from its original position as shown in Fig. (b).
- 3. NEUTRAL EQUILIBRIUM:** A body is said to be in a neutral equilibrium, if it occupies a new position (and remains at rest in this position) after slightly displaced from its position of rest. This happens when no additional force sets up due to the displacement. A smooth cylinder lying on a horizontal plane is in neutral equilibrium as shown in Fig. (c).

UNIT - 3

CENTROID, AREA AND MASS MOMENT OF INERTIA

CENTRE OF GRAVITY: The point, through which the whole weight of the body acts, irrespective of its position, is known as centre of gravity (briefly written as C.G.). It may be noted that everybody has one and only one centre of gravity.

CENTROID: The plane figures (like triangle, quadrilateral, circle etc.) have only areas, but no mass. The centre of area of such figures is known as centroid. The method of finding out the centroid of a figure is the same as that of finding out the centre of gravity of a body.

CENTRE OF GRAVITY BY GEOMETRICAL CONSIDERATIONS:

The centre of gravity of simple figures may be found out from the geometry of the figure as given below.

1. The centre of gravity of uniform rod is at its middle point.
2. The centre of gravity of a rectangle (or a parallelogram) is at the point, where its diagonals meet each other. It is also a middle point of the length as well as the breadth of the rectangle as shown in Fig.

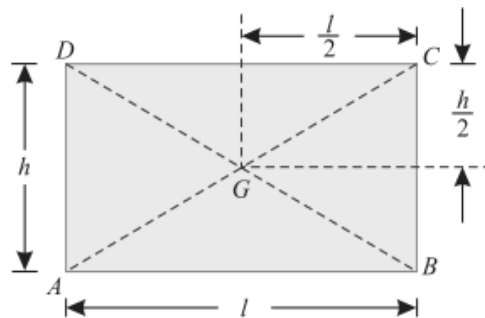

3. The centre of gravity of a triangle is at the point, where the three medians (a median is a line connecting the vertex and middle point of the opposite side) of the triangle meet as shown in Fig.

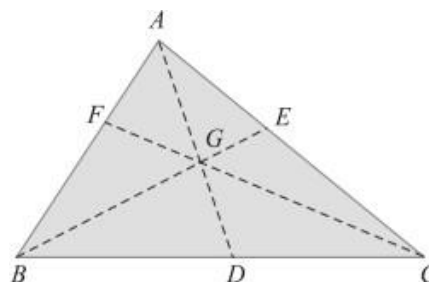

4. The centre of gravity of a trapezium with parallel sides a and b is at a distance of

$$\frac{h}{3} \times \left(\frac{b+2a}{b+a} \right)$$

measured from the side b as shown in Fig.

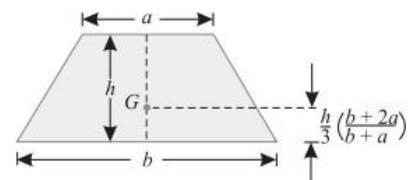

5. The centre of gravity of a semicircle is at a distance of $\frac{4r}{3\pi}$ from its base measured along the vertical radius as shown in Fig.

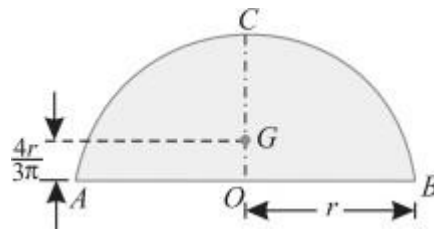

6. The centre of gravity of a circular sector making semi-vertical angle α is at a distance of $\frac{2r \sin \alpha}{3 \alpha}$

7. The centre of gravity of a cube is at a distance of $l/2$ from every face (where l is the length of each side).

8. The centre of gravity of a sphere is at a distance of $d/2$ from every point (where d is the diameter of the sphere).

9. The centre of gravity of a hemisphere is at a distance of $3r/8$ from its base, measured along the vertical radius as shown in Fig.

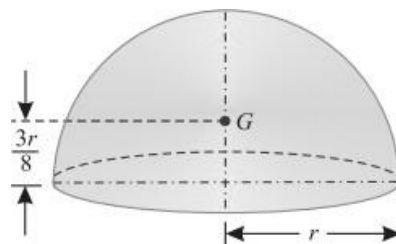

10. The centre of gravity of right circular solid cone is at a distance of $h/4$ from its base, measured along the vertical axis as shown in Fig.

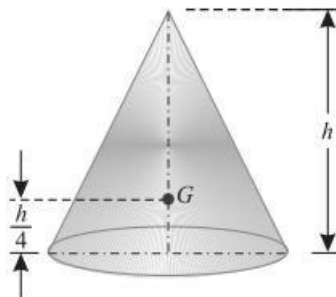

AXIS OF REFERENCE:

The centre of gravity of a body is always calculated with reference to some assumed axis known as axis of reference (or sometimes with reference to some point of reference). The axis of reference, of plane figures, is generally taken as the lowest line of the figure for calculating \bar{y} and the left line of the figure for calculating \bar{x} .

CENTRE OF GRAVITY OF PLANE FIGURES:

Let \bar{x} and \bar{y} be the co-ordinates of the centre of gravity with respect to some axis of reference, then

$$\bar{x} = \frac{a_1 x_1 + a_2 x_2 + a_3 x_3 + \dots}{a_1 + a_2 + a_3}$$

and

$$\bar{y} = \frac{a_1 y_1 + a_2 y_2 + a_3 y_3 + \dots}{a_1 + a_2 + a_3 + \dots}$$

where a_1, a_2, a_3, \dots etc., are the areas into which the whole figure is divided x_1, x_2, x_3, \dots etc., are the respective co-ordinates of the areas a_1, a_2, a_3, \dots on $X-X$ axis with respect to same axis of reference.

y_1, y_2, y_3, \dots etc., are the respective co-ordinates of the areas a_1, a_2, a_3, \dots on $Y-Y$ axis with respect to same axis of the reference.

CENTRE OF GRAVITY OF SYMMETRICAL SECTIONS:

Sometimes, the given section, whose centre of gravity is required to be found out, is symmetrical about $X-X$ axis or $Y-Y$ axis. In such cases, the procedure for calculating the centre of gravity of the body is very much simplified; as we have only to calculate either \bar{x} or \bar{y} . This is due to the reason that the centre of gravity of the body will lie on the axis of symmetry.

EXAMPLE: Find the centre of gravity of a 100 mm × 150 mm × 30 mm T-section.

Solution. As the section is symmetrical about $Y-Y$ axis, bisecting the web, therefore its centre of gravity will lie on this axis. Split up the section into two rectangles $ABCH$ and $DEFG$ as shown in Fig 6.10.

Let bottom of the web FE be the axis of reference.

(i) Rectangle $ABCH$

$$a_1 = 100 \times 30 = 3000 \text{ mm}^2$$

and

$$y_1 = \left(150 - \frac{30}{2}\right) = 135 \text{ mm}$$

(ii) Rectangle $DEFG$

$$a_2 = 120 \times 30 = 3600 \text{ mm}^2$$

and

$$y_2 = \frac{120}{2} = 60 \text{ mm}$$

We know that distance between centre of gravity of the section and bottom of the flange FE ,

$$\begin{aligned} \bar{y} &= \frac{a_1 y_1 + a_2 y_2}{a_1 + a_2} = \frac{(3000 \times 135) + (3600 \times 60)}{3000 + 3600} \text{ mm} \\ &= 94.1 \text{ mm} \quad \text{Ans.} \end{aligned}$$

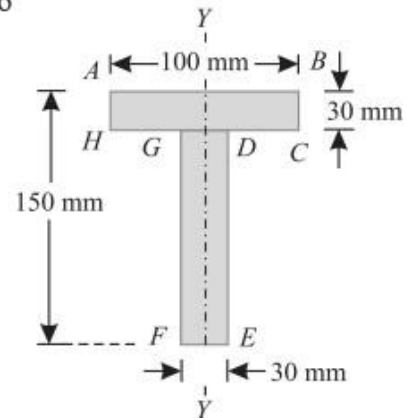

EXAMPLE: An I-section has the following dimensions in mm units:

Bottom flange = 300×100

Top flange = 150×50

Web = 300×50

Determine mathematically the position of centre of gravity of the section.

Solution. As the section is symmetrical about Y-Y axis, bisecting the web, therefore its centre of gravity will lie on this axis. Now split up the section into three rectangles as shown in Fig.

Let bottom of the bottom flange be the axis of reference.

(i) *Bottom flange*

$$a_1 = 300 \times 100 = 30\,000 \text{ mm}^2$$

and
$$y_1 = \frac{100}{2} = 50 \text{ mm}$$

(ii) *Web*

$$a_2 = 300 \times 50 = 15\,000 \text{ mm}^2$$

and
$$y_2 = 100 + \frac{300}{2} = 250 \text{ mm}$$

(iii) *Top flange*

$$a_3 = 150 \times 50 = 7\,500 \text{ mm}^2$$

and
$$y_3 = 100 + 300 + \frac{50}{2} = 425 \text{ mm}$$

We know that distance between centre of gravity of the section and bottom of the flange,

$$\begin{aligned} \bar{y} &= \frac{a_1 y_1 + a_2 y_2 + a_3 y_3}{a_1 + a_2 + a_3} \\ &= \frac{(30\,000 \times 50) + (15\,000 \times 250) + (7\,500 \times 425)}{30\,000 + 15\,000 + 7\,500} = 160.7 \text{ mm} \quad \text{Ans.} \end{aligned}$$

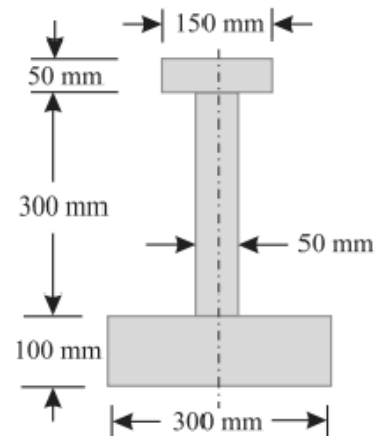

CENTRE OF GRAVITY OF UNSYMMETRICAL SECTIONS:

Sometimes, the given section, whose centre of gravity is required to be found out, is not symmetrical either about X-X axis or Y-Y axis. In such cases, we have to find out both the values of \bar{x} and \bar{y}

EXAMPLE: Find the centroid of an unequal angle section $100 \text{ mm} \times 80 \text{ mm} \times 20 \text{ mm}$.

Solution. As the section is not symmetrical about any axis, therefore we have to find out the values of \bar{x} and \bar{y} for the angle section. Split up the section into two rectangles as shown in Fig.

Let left face of the vertical section and bottom face of the horizontal section be axes of reference.

Let left face of the vertical section and bottom face of the horizontal section be axes of reference.

(i) *Rectangle 1*

$$a_1 = 100 \times 20 = 2000 \text{ mm}^2$$

$$x_1 = \frac{20}{2} = 10 \text{ mm}$$

and $y_1 = \frac{100}{2} = 50 \text{ mm}$

(ii) *Rectangle 2*

$$a_2 = (80 - 20) \times 20 = 1200 \text{ mm}^2$$

$$x_2 = 20 + \frac{60}{2} = 50 \text{ mm}$$

and $y_2 = \frac{20}{2} = 10 \text{ mm}$

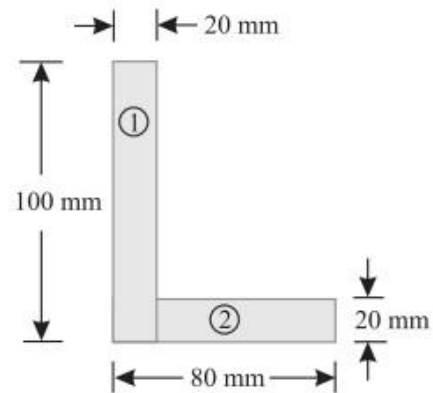

We know that distance between centre of gravity of the section and left face,

$$\bar{x} = \frac{a_1 x_1 + a_2 x_2}{a_1 + a_2} = \frac{(2000 \times 10) + (1200 \times 50)}{2000 + 1200} = 25 \text{ mm} \quad \text{Ans.}$$

Similarly, distance between centre of gravity of the section and bottom face,

$$\bar{y} = \frac{a_1 y_1 + a_2 y_2}{a_1 + a_2} = \frac{(2000 \times 50) + (1200 \times 10)}{2000 + 1200} = 35 \text{ mm} \quad \text{Ans.}$$

EXAMPLE: A body consists of a right circular solid cone of height 40 mm and radius 30 mm placed on a solid hemisphere of radius 30 mm of the same material. Find the position of centre of gravity of the body.

Solution. As the body is symmetrical about *Y-Y* axis, therefore its centre of gravity will lie on this axis as shown in Fig. Let bottom of the hemisphere (*D*) be the point of reference.

(i) *Hemisphere*

$$v_1 = \frac{2\pi}{3} \times r^3 = \frac{2\pi}{3} (30)^3 \text{ mm}^3$$

$$= 18\,000 \pi \text{ mm}^3$$

and $y_1 = \frac{5r}{8} = \frac{5 \times 30}{8} = 18.75 \text{ mm}$

(ii) *Right circular cone*

$$v_2 = \frac{\pi}{3} \times r^2 \times h = \frac{\pi}{3} \times (30)^2 \times 40 \text{ mm}^3$$

$$= 12\,000 \pi \text{ mm}^3$$

and $y_2 = 30 + \frac{40}{4} = 40 \text{ mm}$

We know that distance between centre of gravity of the body and bottom of hemisphere *D*,

$$\bar{y} = \frac{v_1 y_1 + v_2 y_2}{v_1 + v_2} = \frac{(18\,000\pi \times 18.75) + (12\,000\pi \times 40)}{18\,000\pi + 12\,000\pi} \text{ mm}$$

$$= 27.3 \text{ mm} \quad \text{Ans.}$$

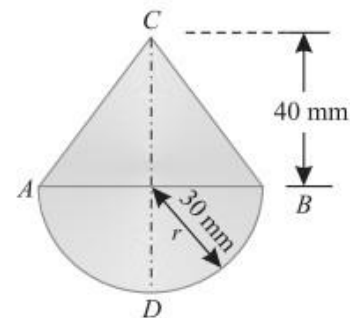

MOMENT OF INERTIA: The moment of a force (P) about a point, is the product of the force and perpendicular distance (x) between the point and the line of action of the force (*i.e.* $P \cdot x$). This moment is also called first moment of force. If this moment is again multiplied by the perpendicular distance (x) between the point and the line of action of the force *i.e.* $P \cdot x(x) = P \cdot x^2$, then this quantity is called moment of the moment of a force or second moment of force or moment of inertia (briefly written as M.I.).

MOMENT OF INERTIA OF A PLANE AREA:

Consider a plane area, whose moment of inertia is required to be found out. Split up the whole area into a number of small elements.

Let $a_1, a_2, a_3, \dots =$ Areas of small elements, and
 $r_1, r_2, r_3, \dots =$ Corresponding distances of the elements from the line about which the moment of inertia is required to be found out.

Now the moment of inertia of the area,

$$I = a_1 r_1^2 + a_2 r_2^2 + a_3 r_3^2 + \dots$$

$$= \sum a r^2$$

UNITS OF MOMENT OF INERTIA:

As a matter of fact the units of moment of inertia of a plane area depend upon the units of the area and the length. e.g.

1. If area is in m^2 and the length is also in m , the moment of inertia is expressed in m^4
2. If area in mm^2 and the length is also in mm , then moment of inertia is expressed in mm^4 .

MOMENT OF INERTIA BY INTEGRATION:

The moment of inertia of an area may also be found out by the method of integration as discussed below:

Consider a plane figure, whose moment of inertia is required to be found out about $X-X$ axis and $Y-Y$ axis as shown in Fig. Let us divide the whole area into a no. of strips. Consider one of these strips.

Let $dA =$ Area of the strip
 $x =$ Distance of the centre of gravity of the strip on $X-X$ axis and
 $y =$ Distance of the centre of gravity of the strip on $Y-Y$ axis.

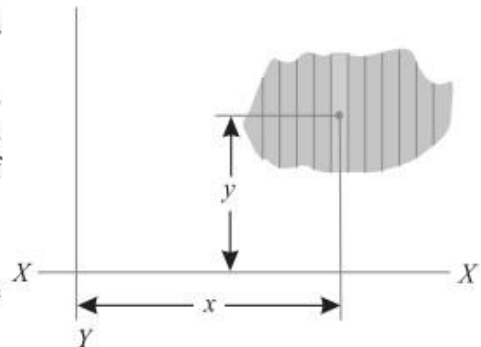

. Moment of inertia by integration.

We know that the moment of inertia of the strip about $Y-Y$ axis
 $= dA \cdot x^2$

Now the moment of inertia of the whole area may be found out by integrating above equation. *i.e.*,

$$I_{YY} = \sum dA \cdot x^2$$

Similarly $I_{XX} = \sum dA \cdot y^2$

MOMENT OF INERTIA OF A RECTANGULAR SECTION:

Consider a rectangular section $ABCD$ as shown in Fig. whose moment of inertia is required to be found out.

Let b = Width of the section and
 d = Depth of the section.

Now consider a strip PQ of thickness dy parallel to $X-X$ axis and at a distance y from it as shown in the figure

\therefore Area of the strip
 $= b \cdot dy$

We know that moment of inertia of the strip about $X-X$ axis,
 $= \text{Area} \times y^2 = (b \cdot dy) y^2 = b \cdot y^2 \cdot dy$

Now *moment of inertia of the whole section may be found out by integrating the above equation for the whole length of the lamina *i.e.* from $-\frac{d}{2}$ to $+\frac{d}{2}$,

$$I_{xx} = \int_{-\frac{d}{2}}^{+\frac{d}{2}} b \cdot y^2 \cdot dy = b \int_{-\frac{d}{2}}^{+\frac{d}{2}} y^2 \cdot dy$$

$$= b \left[\frac{y^3}{3} \right]_{-\frac{d}{2}}^{+\frac{d}{2}} = b \left[\frac{(d/2)^3}{3} - \frac{(-d/2)^3}{3} \right] = \frac{bd^3}{12}$$

Similarly, $I_{yy} = \frac{db^3}{12}$

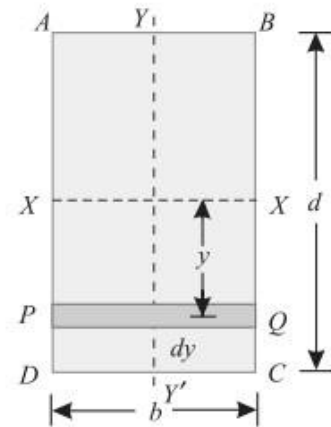

Rectangular section.

MOMENT OF INERTIA OF A HOLLOW RECTANGULAR SECTION:

Consider a hollow rectangular section, in which $ABCD$ is the main section and $EFGH$ is the cut out section as shown in Fig

Let b = Breadth of the outer rectangle,
 d = Depth of the outer rectangle and
 b_1, d_1 = Corresponding values for the cut out rectangle.

We know that the moment of inertia, of the outer rectangle $ABCD$ about $X-X$ axis

$$= \frac{bd^3}{12} \quad \dots(i)$$

and moment of inertia of the cut out rectangle $EFGH$ about $X-X$ axis

$$= \frac{b_1 d_1^3}{12} \quad \dots(ii)$$

\therefore M.I. of the hollow rectangular section about $X-X$ axis,

$$I_{xx} = \text{M.I. of rectangle } ABCD - \text{M.I. of rectangle } EFGH$$

$$= \frac{bd^3}{12} - \frac{b_1 d_1^3}{12}$$

Similarly, $I_{yy} = \frac{db^3}{12} - \frac{d_1 b_1^3}{12}$

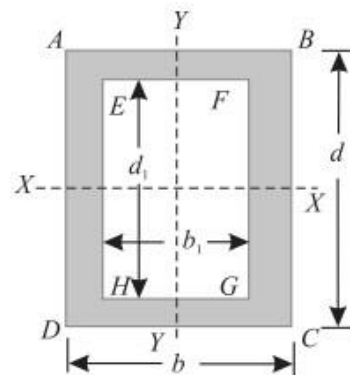

Hollow rectangular section.

THEOREM OF PERPENDICULAR AXIS:

It states, If I_{XX} and I_{YY} be the moments of inertia of a plane section about two perpendicular axis meeting at O , the moment of inertia I_{ZZ} about the axis $Z-Z$, perpendicular to the plane and passing through the intersection of $X-X$ and $Y-Y$ is given by:

$$I_{ZZ} = I_{XX} + I_{YY}$$

Proof :

Consider a small lamina (P) of area da having co-ordinates as x and y along OX and OY two mutually perpendicular axes on a plane section as shown in Fig.

Now consider a plane OZ perpendicular to OX and OY . Let (r) be the distance of the lamina (P) from $Z-Z$ axis such that $OP = r$.

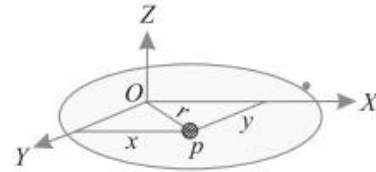

Theorem of perpendicular axis.

From the geometry of the figure, we find that

$$r^2 = x^2 + y^2$$

We know that the moment of inertia of the lamina P about $X-X$ axis,

$$I_{XX} = da \cdot y^2$$

...[$\because I = \text{Area} \times (\text{Distance})^2$]

Similarly,

$$I_{YY} = da \cdot x^2$$

and

$$I_{ZZ} = da \cdot r^2 = da (x^2 + y^2)$$

...($\because r^2 = x^2 + y^2$)

$$= da \cdot x^2 + da \cdot y^2 = I_{YY} + I_{XX}$$

MOMENT OF INERTIA OF A CIRCULAR SECTION:

Consider a circle $ABCD$ of radius (r) with centre O and $X-X'$ and $Y-Y'$ be two axes of reference through O as shown in Fig.

Now consider an elementary ring of radius x and thickness dx . Therefore area of the ring,

$$da = 2 \pi x \cdot dx$$

and moment of inertia of ring, about $X-X$ axis or $Y-Y$ axis

$$= \text{Area} \times (\text{Distance})^2$$

$$= 2 \pi x \cdot dx \times x^2$$

$$= 2 \pi x^3 \cdot dx$$

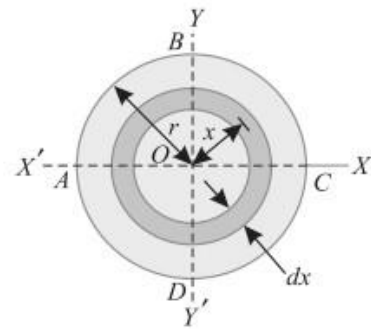

Circular section.

Now moment of inertia of the whole section, about the central axis, can be found out by integrating the above equation for the whole radius of the circle *i.e.*, from 0 to r .

$$\therefore I_{ZZ} = \int_0^r 2 \pi x^3 \cdot dx = 2 \pi \int_0^r x^3 \cdot dx$$

$$I_{ZZ} = 2 \pi \left[\frac{x^4}{4} \right]_0^r = \frac{\pi}{2} (r)^4 = \frac{\pi}{32} (d)^4$$

... (substituting $r = \frac{d}{2}$)

We know from the Theorem of Perpendicular Axis that

$$I_{XX} + I_{YY} = I_{ZZ}$$

$$* I_{XX} = I_{YY} = \frac{I_{ZZ}}{2} = \frac{1}{2} \times \frac{\pi}{32} (d)^4 = \frac{\pi}{64} (d)^4$$

MOMENT OF INERTIA OF A HOLLOW CIRCULAR SECTION:

Consider a hollow circular section as shown in Fig. whose moment of inertia is required to be found out.

Let $D =$ Diameter of the main circle, and
 $d =$ Diameter of the cut out circle.

We know that the moment of inertia of the main circle about X-X axis

$$= \frac{\pi}{64} (D)^4$$

and moment of inertia of the cut-out circle about X-X axis

$$= \frac{\pi}{64} (d)^4$$

\therefore Moment of inertia of the hollow circular section about X-X axis,

$I_{XX} =$ Moment of inertia of main circle – Moment of inertia of cut out circle,

$$= \frac{\pi}{64} (D)^4 - \frac{\pi}{64} (d)^4 = \frac{\pi}{64} (D^4 - d^4)$$

Similarly, $I_{YY} = \frac{\pi}{64} (D^4 - d^4)$

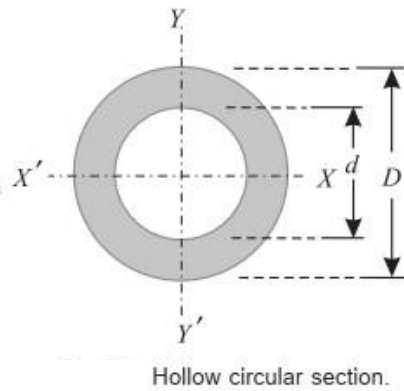

THEOREM OF PARALLEL AXIS:

It states, *If the moment of inertia of a plane area about an axis through its centre of gravity is denoted by I_G , then moment of inertia of the area about any other axis AB, parallel to the first, and at a distance h from the centre of gravity is given by:*

$$I_{AB} = I_G + ah^2$$

where

$I_{AB} =$ Moment of inertia of the area about an axis AB,

$I_G =$ Moment of Inertia of the area about its centre of gravity

$a =$ Area of the section, and

$h =$ Distance between centre of gravity of the section and axis AB.

Proof

Consider a strip of a circle, whose moment of inertia is required to be found out about a line AB as shown in Fig.

Let

$\delta a =$ Area of the strip

$y =$ Distance of the strip from the centre of gravity the section and

$h =$ Distance between centre of gravity of the section and the axis AB.

We know that moment of inertia of the whole section about an axis passing through the centre of gravity of the section

$$= \delta a \cdot y^2$$

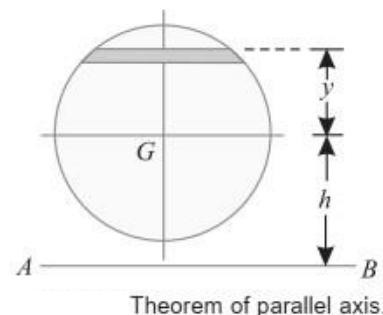

and moment of inertia of the whole section about an axis passing through its centre of gravity,

$$I_G = \sum \delta a \cdot y^2$$

∴ Moment of inertia of the section about the axis AB ,

$$\begin{aligned} I_{AB} &= \sum \delta a (h + y)^2 = \sum \delta a (h^2 + y^2 + 2 h y) \\ &= (\sum h^2 \cdot \delta a) + (\sum y^2 \cdot \delta a) + (\sum 2 h y \cdot \delta a) \\ &= a h^2 + I_G + 0 \end{aligned}$$

It may be noted that $\sum h^2 \cdot \delta a = a h^2$ and $\sum y^2 \cdot \delta a = I_G$ [as per equation (i) above] and $\sum \delta a \cdot y$ is the algebraic sum of moments of all the areas, about an axis through centre of gravity of the section and is equal to $a \cdot \bar{y}$, where \bar{y} is the distance between the section and the axis passing through the centre of gravity, which obviously is zero.

MOMENT OF INERTIA OF A TRIANGULAR SECTION:

Consider a triangular section ABC whose moment of inertia is required to be found out.

Let b = Base of the triangular section and
 h = Height of the triangular section.

Now consider a small strip PQ of thickness dx at a distance of x from the vertex A as shown in Fig. From the geometry of the figure, we find that the two triangles APQ and ABC are similar. Therefore

$$\frac{PQ}{BC} = \frac{x}{h} \quad \text{or} \quad PQ = \frac{BC \cdot x}{h} = \frac{bx}{h}$$

We know that area of the strip PQ

$$= \frac{bx}{h} \cdot dx$$

and moment of inertia of the strip about the base BC

$$= \text{Area} \times (\text{Distance})^2 = \frac{bx}{h} dx (h - x)^2 = \frac{bx}{h} (h - x)^2 dx$$

Now moment of inertia of the whole triangular section may be found out by integrating the above equation for the whole height of the triangle *i.e.*, from 0 to h .

$$I_{BC} = \int_0^h \frac{bx}{h} (h - x)^2 dx$$

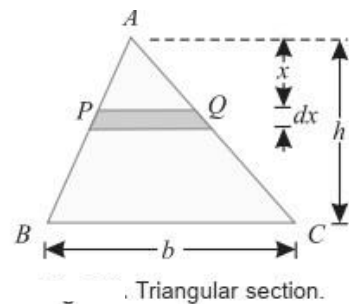

(∵ BC = base = b)

$$\begin{aligned}
&= \frac{b}{h} \int_0^h x (h^2 + x^2 - 2hx) dx \\
&= \frac{b}{h} \int_0^h (xh^2 + x^3 - 2hx^2) dx \\
&= \frac{b}{h} \left[\frac{x^2 h^2}{2} + \frac{x^4}{4} - \frac{2hx^3}{3} \right]_0^h = \frac{bh^3}{12}
\end{aligned}$$

We know that distance between centre of gravity of the triangular section and base BC ,

$$d = \frac{h}{3}$$

\therefore Moment of inertia of the triangular section about an axis through its centre of gravity and parallel to $X-X$ axis,

$$\begin{aligned}
I_G &= I_{BC} - ad^2 && \dots (\because I_{XX} = I_G + ah^2) \\
&= \frac{bh^3}{12} - \left(\frac{bh}{2}\right) \left(\frac{h}{3}\right)^2 = \frac{bh^3}{36}
\end{aligned}$$

MOMENT OF INERTIA OF A SEMICIRCULAR SECTION:

Consider a semicircular section ABC whose moment of inertia is required to be found out as shown in Fig.

Let r = Radius of the semicircle.

We know that moment of inertia of the semicircular section about the base AC is equal to half the moment of inertia of the circular section about AC . Therefore moment of inertia of the semicircular section ABC about the base AC ,

$$I_{AC} = \frac{1}{2} \times \frac{\pi}{64} \times (d)^4 = 0.393 r^4$$

We also know that area of semicircular section,

$$a = \frac{1}{2} \times \pi r^2 = \frac{\pi r^2}{2}$$

and distance between centre of gravity of the section and the base AC ,

$$h = \frac{4r}{3\pi}$$

\therefore Moment of inertia of the section through its centre of gravity and parallel to $x-x$ axis,

$$\begin{aligned}
I_G &= I_{AC} - ah^2 = \left[\frac{\pi}{8} \times (r)^4 \right] - \left[\frac{\pi r^2}{2} \left(\frac{4r}{3\pi} \right)^2 \right] \\
&= \left[\frac{\pi}{8} \times (r)^4 \right] - \left[\frac{8}{9\pi} \times (r)^4 \right] = 0.11 r^4
\end{aligned}$$

Note. The moment of inertia about $y-y$ axis will be the same as that about the base AC i.e., $0.393 r^4$.

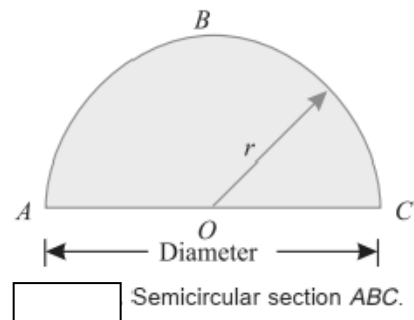

MOMENT OF INERTIA OF A COMPOSITE SECTION:

The moment of inertia of a composite section may be found out by the following steps :

1. First of all, split up the given section into plane areas (*i.e.*, rectangular, triangular, circular etc., and find the centre of gravity of the section).
2. Find the moments of inertia of these areas about their respective centres of gravity.
3. Now transfer these moment of inertia about the required axis (*AB*) by the Theorem of Parallel Axis, *i.e.*,

$$I_{AB} = I_G + ah^2$$

where I_G = Moment of inertia of a section about its centre of gravity and parallel to the axis.
 a = Area of the section,
 h = Distance between the required axis and centre of gravity of the section.

4. The moments of inertia of the given section may now be obtained by the algebraic sum of the moment of inertia about the required axis.

EXAMPLE: Find the moment of inertia of a T-section with flange as 150 mm × 50 mm and web as 150 mm × 50 mm about X-X and Y-Y axes through the centre of gravity of the section.

Solution. The given T-section is shown in Fig. 7.11.

First of all, let us find out centre of gravity of the section. As the section is symmetrical about Y-Y axis, therefore its centre of gravity will lie on this axis. Split up the whole section into two rectangles *viz.*, 1 and 2 as shown in figure. Let bottom of the web be the axis of reference.

(i) Rectangle (1)

$$a_1 = 150 \times 50 = 7500 \text{ mm}^2$$

and $y_1 = 150 + \frac{50}{2} = 175 \text{ mm}$

(ii) Rectangle (2)

$$a_2 = 150 \times 50 = 7500 \text{ mm}^2$$

and $y_2 = \frac{150}{2} = 75 \text{ mm}$

We know that distance between centre of gravity of the section and bottom of the web,

$$\bar{y} = \frac{a_1 y_1 + a_2 y_2}{a_1 + a_2} = \frac{(7500 \times 175) + (7500 \times 75)}{7500 + 7500} = 125 \text{ mm}$$

Moment of inertia about X-X axis

We also know that M.I. of rectangle (1) about an axis through its centre of gravity and parallel to X-X axis.

$$I_{G1} = \frac{150 (50)^3}{12} = 1.5625 \times 10^6 \text{ mm}^4$$

and distance between centre of gravity of rectangle (1) and X-X axis,

$$h_1 = 175 - 125 = 50 \text{ mm}$$

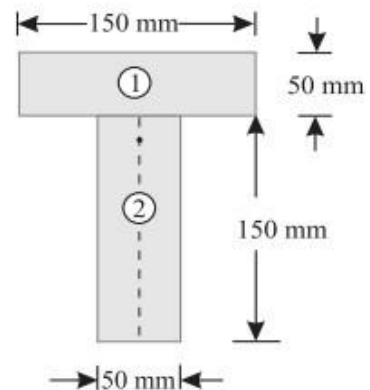

∴ Moment of inertia of rectangle (1) about X-X axis

$$I_{G1} + a_1 h_1^2 = (1.5625 \times 10^6) + [7500 \times (50)^2] = 20.3125 \times 10^6 \text{ mm}^4$$

Similarly, moment of inertia of rectangle (2) about an axis through its centre of gravity and parallel to X-X axis,

$$I_{G2} = \frac{50 (150)^3}{12} = 14.0625 \times 10^6 \text{ mm}^4$$

and distance between centre of gravity of rectangle (2) and X-X axis,

$$h_2 = 125 - 75 = 50 \text{ mm}$$

∴ Moment of inertia of rectangle (2) about X-X axis

$$= I_{G2} + a_2 h_2^2 = (14.0625 \times 10^6) + [7500 \times (50)^2] = 32.8125 \times 10^6 \text{ mm}^4$$

Now moment of inertia of the whole section about X-X axis,

$$I_{XX} = (20.3125 \times 10^6) + (32.8125 \times 10^6) = 53.125 \times 10^6 \text{ mm}^4 \quad \text{Ans.}$$

Moment of inertia about Y-Y axis

We know that M.I. of rectangle (1) about Y-Y axis

$$= \frac{50 (150)^3}{12} = 14.0625 \times 10^6 \text{ mm}^4$$

and moment of inertia of rectangle (2) about Y-Y axis,

$$= \frac{150 (50)^3}{12} = 1.5625 \times 10^6 \text{ mm}^4$$

Now moment of inertia of the whole section about Y-Y axis,

$$I_{YY} = (14.0625 \times 10^6) + (1.5625 \times 10^6) = 15.625 \times 10^6 \text{ mm}^4 \quad \text{Ans.}$$

EXAMPLE: An I-section is made up of three rectangles as shown in Fig. Find the moment of inertia of the section about the horizontal axis passing through the centre of gravity of the section.

Solution. First of all, let us find out centre of gravity of the section. As the section is symmetrical about Y-Y axis, therefore its centre of gravity will lie on this axis. Split up the whole section into three rectangles 1, 2 and 3 as shown in Fig. . Let bottom face of the bottom flange be the axis of reference.

(i) Rectangle 1

$$a_1 = 60 \times 20 = 1200 \text{ mm}$$

and $y_1 = 20 + 100 + \frac{20}{2} = 130 \text{ mm}$

(ii) Rectangle 2

$$a_2 = 100 \times 20 = 2000 \text{ mm}^2$$

and $y_2 = 20 + \frac{100}{2} = 70 \text{ mm}$

(iii) Rectangle 3

$$a_3 = 100 \times 20 = 2000 \text{ mm}^2$$

and $y_3 = \frac{20}{2} = 10 \text{ mm}$

We know that the distance between centre of gravity of the section and bottom face,

$$\bar{y} = \frac{a_1 y_1 + a_2 y_2 + a_3 y_3}{a_1 + a_2 + a_3} = \frac{(1200 \times 130) + (2000 \times 70) + (2000 \times 10)}{1200 + 2000 + 2000} \text{ mm}$$

$$= 60.8 \text{ mm}$$

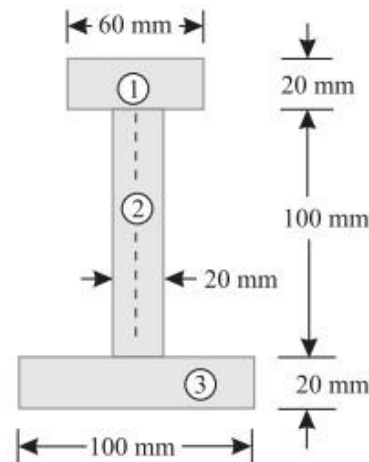

We know that moment of inertia of rectangle (1) about an axis through its centre of gravity and parallel to X-X axis,

$$I_{G1} = \frac{60 \times (20)^3}{12} = 40 \times 10^3 \text{ mm}^4$$

and distance between centre of gravity of rectangle (1) and X-X axis,

$$h_1 = 130 - 60.8 = 69.2 \text{ mm}$$

∴ Moment of inertia of rectangle (1) about X-X axis,

$$= I_{G1} + a_1 h_1^2 = (40 \times 10^3) + [1200 \times (69.2)^2] = 5786 \times 10^3 \text{ mm}^4$$

Similarly, moment of inertia of rectangle (2) about an axis through its centre of gravity and parallel to X-X axis,

$$I_{G2} = \frac{20 \times (100)^3}{12} = 1666.7 \times 10^3 \text{ mm}^4$$

and distance between centre of gravity of rectangle (2) and X-X axis,

$$h_2 = 70 - 60.8 = 9.2 \text{ mm}$$

∴ Moment of inertia of rectangle (2) about X-X axis,

$$= I_{G2} + a_2 h_2^2 = (1666.7 \times 10^3) + [2000 \times (9.2)^2] = 1836 \times 10^3 \text{ mm}^4$$

Now moment of inertia of rectangle (3) about an axis through its centre of gravity and parallel to X-X axis,

$$I_{G3} = \frac{100 \times (20)^3}{12} = 66.7 \times 10^3 \text{ mm}^4$$

and distance between centre of gravity of rectangle (3) and X-X axis,

$$h_3 = 60.8 - 10 = 50.8 \text{ mm}$$

∴ Moment of inertia of rectangle (3) about X-X axis,

$$= I_{G3} + a_3 h_3^2 = (66.7 \times 10^3) + [2000 \times (50.8)^2] = 5228 \times 10^3 \text{ mm}^4$$

Now moment of inertia of the whole section about X-X axis,

$$I_{XX} = (5786 \times 10^3) + (1836 \times 10^3) + (5228 \times 10^3) = 12\,850 \times 10^3 \text{ mm}^4 \quad \text{Ans.}$$

UNIT -4 & 5 DYNAMICS

KINETICS: It is the branch of Dynamics, which deals with the bodies in motion due to the application of forces.

KINEMATICS: It is that branch of Dynamics, which deals with the bodies in motion, without any reference to the forces which are responsible for the motion.

PRINCIPLE OF DYNAMICS:

1. A body can possess acceleration only when some force is applied on it. Or in other words, if no force is applied on the body, then there will be no acceleration, and the body will continue to move with the existing uniform velocity.
2. The force applied on a body is proportional to the product of the mass of the body and the acceleration produced in it.

NEWTON'S LAWS OF MOTION:

Following are the three laws of motion, which were enunciated by Newton,

1. Newton's First Law of Motion states, "Everybody continues in its state of rest or of uniform motion, in a straight line, unless it is acted upon by some external force."
2. Newton's Second Law of Motion states, "The rate of change of momentum is directly proportional to the impressed force, and takes place in the same direction, in which the force acts."

$$F = ma = \text{Mass} \times \text{Acceleration}$$

3. Newton's Third Law of Motion states, "To every action, there is always an equal and opposite reaction."

D'ALEMBERT'S PRINCIPLE:

It states, "If a rigid body is acted upon by a system of forces, this system may be reduced to a single resultant force whose magnitude, direction and the line of action may be found out by the methods of graphic statics."

We know that force acting on a body.

$$P = ma \qquad \dots(i)$$

The equation (i) may also be written as :

$$P - ma = 0 \qquad \dots(ii)$$

It may be noted that equation (i) is the equation of dynamics whereas the equation (ii) is the equation of statics. The equation (ii) is also known as the equation of dynamic equilibrium under the action of the real force P. This principle is known as D' Alembert's principle.

EQUATIONS OF MOTION:

Let u = Initial velocity,
 v = Final velocity,
 t = Time (in seconds) taken by the particle to change its velocity from u to v .
 a = Uniform positive acceleration, and
 s = Distance travelled in t seconds.

Since in t seconds, the velocity of the particle has increased steadily from (u) to (v) at the rate of a , therefore total increase in velocity = $a t$

$$v = u + at \quad \dots(i)$$

We know that distance travelled by the particle,
 s = Average velocity \times Time

$$s = \left(\frac{u + v}{2} \right) \times t \quad \dots(ii)$$

$$s = \left(\frac{u + u + at}{2} \right) \times t = ut + \frac{1}{2}at^2 \quad \dots(iii)$$

$$v^2 = u^2 + 2as$$

EXAMPLE:

A scooter starts from rest and moves with a constant acceleration of 1.2 m/s^2 . Determine its velocity, after it has travelled for 60 meters.

Solution. Given : Initial velocity (u) = 0 (because it starts from rest) Acceleration (a) = 1.2 m/s^2 and distance travelled (s) = 60 m.

Let v = Final velocity of the scooter.

We know that $v^2 = u^2 + 2as = (0)^2 + 2 \times 1.2 \times 60 = 144$

$$v = 12 \text{ m/s} = \frac{12 \times 3600}{1000} = 43.2 \text{ km.p.h. Ans.}$$

EXAMPLE: A motor car takes 10 seconds to cover 30 meters and 12 seconds to cover 42 meters. Find the uniform acceleration of the car and its velocity at the end of 15 seconds.

Solution. Given : When $t = 10$ seconds, $s = 30$ m and when $t = 12$ seconds, $s = 42$ m.

Uniform acceleration

Let $u =$ Initial velocity of the car, and
 $a =$ Uniform acceleration.

We know that the distance travelled by the car in 10 seconds,

$$30 = ut + \frac{1}{2}at^2 = u \times 10 + \frac{1}{2} \times a(10)^2 = 10u + 50a$$

Multiplying the above equation by 6,

$$180 = 60u + 300a \quad \dots(i)$$

Similarly, distance travelled by the car in 12 seconds,

$$42 = u \times 12 + \frac{1}{2} \times a(12)^2 = 12u + 72a$$

Multiplying the above equation by 5,

$$210 = 60u + 360a \quad \dots(ii)$$

Subtracting equation (i) from (ii),

$$30 = 60a \quad \text{or} \quad a = \frac{30}{60} = 0.5 \text{ m/s}^2 \quad \text{Ans.}$$

Velocity at the end of 15 seconds

Substituting the value of a in equation (i)

$$180 = 60u + (300 \times 0.5) = 60u + 150$$

$$\therefore u = \frac{(180 - 150)}{60} = 0.5 \text{ m/s}$$

We know that the velocity of the car after 15 seconds,

$$v = u + at = 0.5 + (0.5 \times 15) = 8 \text{ m/s} \quad \text{Ans.}$$

WORK: Whenever a force acts on a body, and the body undergoes some displacement, then work is said to be done. *e.g.*, if a force P , acting on a body, causes it to move through a distance s as shown in Fig.(a). Then work done by the force P

$$= \text{Force} \times \text{Distance}$$

$$= P \times s$$

Sometimes, the force P does not act in the direction of motion of the body, or in other words, the body does not move in the direction of the force as shown in Fig.(b).

Then work done by the force P

$$= \text{Component of the force in the direction of motion} \times \text{Distance}$$

$$= P \cos \theta \times s$$

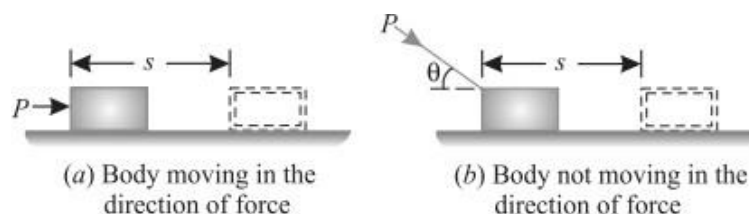

UNITS OF WORK:

The units of work (or work done) are :

1. **One N-m:** It is the work done by a force of 1 N, when it displaces the body through 1 m. It is called joule (briefly written as J), Mathematically.

$$1 \text{ joule} = 1 \text{ N-m}$$

2. **One kN-m:** It is the work done by a force of 1 kN, when it displaces the body through 1 m. It is also called kilojoule (briefly written as kJ). Mathematically.

$$1 \text{ kilo-joule} = 1 \text{ kN-m}$$

POWER:

The power may be defined as the rate of doing work. It is thus the measure of performance of engines. e.g. an engine doing a certain amount of work, in one second, will be twice as powerful as an engine doing the same amount of work in two seconds.

UNITS OF POWER:

In S.I. units, the unit of power is watt (briefly written as W) which is equal to 1 N-m/s or 1 J/s. Generally, a bigger unit of power (kW) is used, which is equal to 10^3 W. Sometimes, a still bigger unit of power (MW) is also used, which is equal to 10^6 W.

ENERGY:

The energy may be defined as the capacity to do work. It exists in many forms i.e., mechanical, electrical chemical, heat, light etc. But in this subject, we shall deal in mechanical energy only.

UNITS OF ENERGY:

Since the energy of a body is measured by the work it can do, therefore the units of energy will be the same as those of the work.

POTENTIAL ENERGY:

It is the energy possessed by a body, for doing work, by virtue of its position. e.g.,

1. A body, raised to some height above the ground level, possesses some potential energy, because it can do some work by falling on the earth's surface.
2. Compressed air also possesses potential energy because it can do some work in expanding, to the volume it would occupy at atmospheric pressure.
3. A compressed spring also possesses potential energy, because it can do some work in recovering to its original shape.

Now consider a body of mass (m) raised through a height (h) above the datum level.

We know that work done in raising the body

$$= \text{Weight} \times \text{Distance} = (mg) h = mgh$$

This work (equal to $m.g.h$) is stored in the body as potential energy.

KINETIC ENERGY:

It is the energy, possessed by a body, for doing work by virtue of its mass and velocity of motion.

$$KE = \frac{mv^2}{2}$$

LAW OF CONSERVATION OF ENERGY:

It states "The energy can neither be created nor destroyed, though it can be transformed from one form into any of the forms, in which the energy can exist."

From the above statement, it is clear, that no machine can either create or destroy energy, though it can only transform from one form into another. We know that the output of a machine is always less than the input of the machine. This is due to the reason that a part of the input is utilized in overcoming friction of the machine. This does not mean that this part of energy, which is used in overcoming the friction, has been destroyed. But it reappears in the form of heat energy at the bearings and other rubbing surfaces of the machine, though it is not available to us for useful work.

The above statement may be exemplified as below :

1. In an electrical heater, the electrical energy is converted into heat energy.
2. In an electric bulb, the electrical energy is converted into light energy.
3. In a dynamo, the mechanical energy is converted into electrical energy.

IMPULSE AND MOMENTUM:

Impulse is the change of momentum of an object when the object is acted upon by a force for an interval of time. So, with impulse, you can calculate the change in momentum, or you can use impulse to calculate the average impact force of a collision.

$$\text{Impulse} = \text{Force} \times \text{time}$$

Momentum is the quantity of motion of a moving body, measured as a product of its mass and velocity.

$$\text{Momentum} = \text{mass} \times \text{velocity}$$

PHENOMENON OF COLLISION:

Whenever two elastic bodies collide with each other, the phenomenon of collision takes place as given below :

1. The bodies, immediately after collision, come momentarily to rest.
2. The two bodies tend to compress each other, so long as they are compressed to the maximum value.
3. The two bodies attempt to regain its original shape due to their elasticity. This process of regaining the original shape is called **restitution**.

The time taken by the two bodies in compression, after the instant of collision, is called the time of compression and time for which restitution takes place is called the time of restitution. The sum of the two times of collision and restitution is called time of collision, period of collision, or period of impact.

LAW OF CONSERVATION OF MOMENTUM:

It states, "The total momentum of two bodies remains constant after their collision or any other mutual action." Mathematically

$$m_1 u_1 + m_2 u_2 = m_1 v_1 + m_2 v_2$$

Where; m_1 = Mass of the first body,

u_1 = Initial velocity of the first body,

v_1 = Final velocity of the first body, and

m_2, u_2, v_2 = Corresponding values for the second body.

COEFFICIENT OF RESTITUTION:

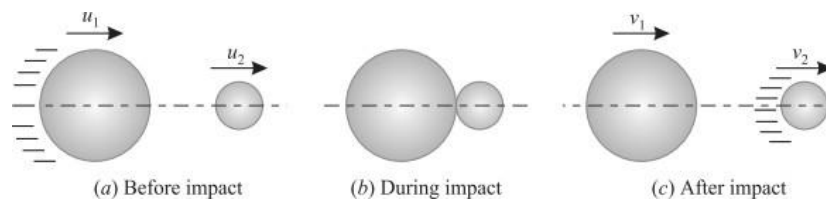

Consider two bodies A and B having a direct impact as shown in Fig. (a).

Let u_1 = Initial velocity of the first body,
 v_1 = Final velocity of the first body, and
 u_2, v_2 = Corresponding values for the second body.

The impact will take place only if u_1 is greater than u_2 .

Therefore, the velocity of approach will be equal to $(u_1 - u_2)$. After impact, the separation of the two bodies will take place, only if v_2 is greater than v_1 . Therefore the velocity of separation will be equal to $(v_2 - v_1)$.

Now as per Newton's Law of Collision of Elastic Bodies:

Velocity of separation = $e \times$ Velocity of approach

$$(v_2 - v_1) = e (u_1 - u_2)$$

where e is a constant of proportionality, and is called the **coefficient of restitution**.

- Its value lies between 0 and 1. It may be noted that if $e = 0$, the two bodies are inelastic. But if $e = 1$, the two bodies are perfectly elastic.

NOTE:

- If the two bodies are moving in the same direction, before or after impact, then the velocity of approach or separation is the difference of their velocities. But if the two bodies are moving in the opposite directions, then the velocity of approach or separation is the algebraic sum of their velocities.

DIRECT COLLISION OF TWO BODIES:

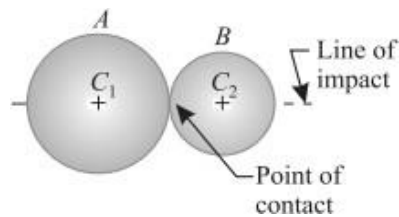

The line of impact, of the two colliding bodies, is the line joining the centres of these bodies and passes through the point of contact or point of collision as shown in Fig. If the two bodies, before impact, are moving along the line of impact, the collision is called as direct impact as shown in Fig.

$$\text{Now; } m_1 u_1 + m_2 u_2 = m_1 v_1 + m_2 v_2$$

NOTES: 1. Since the velocity of a body is a vector quantity, therefore its direction should always be kept in view while solving the examples.

2. If velocity of a body is taken as +ve in one direction, then the velocity in opposite direction should be taken as -ve.

3. If one of the bodies is initially at rest, then such a collision is also called impact.

EXAMPLE: A ball of mass 1 kg moving with a velocity of 2 m/s impinges directly on a ball of mass 2 kg at rest. The first ball, after impinging, comes to rest. Find the velocity of the second ball after the impact and the coefficient of restitution.

Solution. Given : Mass of first ball (m_1) = 1 kg ; Initial velocity of first ball (u_1) = 2 m/s ;
Mass of second ball (m_2) = 2 kg ; Initial velocity of second ball (u_2) = 0 (because it is at rest) and final velocity of first ball after impact (v_1) = 0 (because, it comes to rest)

Velocity of the second ball after impact.

Let v_2 = Velocity of the second ball after impact.

We know from the law of conservation of momentum that

$$m_1 u_1 + m_2 u_2 = m_1 v_1 + m_2 v_2$$
$$(1 \times 2) + (2 \times 0) = (1 \times 0) + (2 \times v_2)$$

$$\therefore 2 = 2v_2$$

$$\text{or } v_2 = 1 \text{ m/s Ans.}$$

Coefficient of restitution

Let e = Coefficient of restitution.

We also know from the law of collision of elastic bodies that

$$(v_2 - v_1) = e (u_1 - u_2)$$
$$(1 - 0) = e (2 - 0)$$

$$\text{or } e = \frac{1}{2} = 0.5 \text{ Ans.}$$

EXAMPLE: The masses of two balls are in the ratio of 2: 1 and their velocities are in the ratio of 1: 2, but in the opposite direction before impact. If the coefficient of restitution be $\frac{5}{6}$, prove that after the impact, each ball will move back with $\frac{5}{6}$ th of its original velocity.

Solution. Given : Mass of first ball (m_1) = $2M$; Mass of second ball (M_2) = M ; Initial velocity of first ball (u_1) = U ; Initial velocity of second ball (u_2) = $-2U$ (Minus sign due to opposite direction) and coefficient of restitution (e) = $\frac{5}{6}$

Let v_1 = Final velocity of the first ball, and
 v_2 = Final velocity of the second ball.

We know from the law of conservation of momentum that

$$m_1u_1 + m_2u_2 = m_1v_1 + m_2v_2$$

$$2M \times U + M(-2U) = 2Mv_1 + Mv_2$$

or $0 = 2Mv_1 + Mv_2$

$\therefore v_2 = -2v_1$... (i)

We also know from the law of collision of elastic bodies that

$$(v_2 - v_1) = e(u_1 - u_2) = \frac{5}{6} [U - (-2U)] = \frac{5U}{2}$$
 ... (ii)

Substituting the value of v_2 from equation (i)

$$[-2v_1 - (v_1)] = \frac{5U}{2} \quad \text{or} \quad v_1 = -\frac{5}{6} \times U$$

Minus sign indicates that the direction of v_1 is opposite to that of U . Thus the first ball will move back with $\frac{5}{6}$ th of its original velocity. **Ans.**

Now substituting the value of v_1 in equation (i),

$$v_2 = -2\left(-\frac{5}{6} \times U\right) = +\frac{5}{6} \times 2U$$

Plus sign indicates that the direction of v_2 is the same as that of v_1 or opposite to that of u_2 . Thus the second ball will also move back with $\frac{5}{6}$ th of its original velocity. **Ans.**

KINEMATICS – RECTILINEAR AND CURVILINEAR MOTION

Kinematics is the study of motion without reference to the cause of motion, i.e. force.

- Rectilinear motion is motion along a straight line.
- Throughout our discussion, all objects will be treated as particles.
- The rotational motion of objects is not considered. Only their translational motion in two dimensions either rectilinear or curvilinear will be discussed

Rectilinear kinematics deals with the following variables

- a) Position
- b) Displacement
- c) Distance travelled
- d) Velocity
- e) Acceleration

a) Position:

- To define position of a particle moving along a straight line, only one co-ordinate is sufficient as that line can be chosen as the X or Y-axis.
- Thus motion of a particle in a straight line is a one dimensional problem.
- An origin has to be chosen on that line and a direction on one side of that origin has to be taken as positive.
- Generally, for a horizontal line (the X-axis) the right side of origin is taken positive and left side negative. For a vertical line, above the origin is taken positive and below the origin negative. For inclined line, one can use a sign convention according to convenience.
- **Position** is a vector quantity as it has both magnitude and direction.
- In one-dimension, vector quantities are represented by scalars with positive or negative sign representing their direction.
- For example, a position of - 5 m on a horizontal line indicates a position 5 m to the left of the origin.

b) Displacement:

- It is defined as the change in position. Displacement is also a vector quantity.

Displacement = Final position - Initial position.

- Note that the position is defined at a particular instant of time, whereas displacement is defined in a finite, non-zero time interval.
- The displacement and position at a particular time will be same if the particle starts from origin, i.e, the initial position is zero.
- For motion along the horizontal, if final position is to the right of the initial position the displacement will be positive. For vertical motion, displacement is positive when final position is above the initial position and negative when final position is below the initial position.

c) Distance travelled :

- It is positive scalar quantity which represents the total length of the path covered by the particle.
- It can be obtained from displacement.
- The magnitude of displacement in any time interval is equal to the distance travelled only when the particle keeps travelling in the same direction throughout that time interval.
- If the particle changes direction, split the time interval into suitable smaller intervals so that in each smaller interval, the particle travels in a particular direction.
- The total distance travelled can then be obtained by adding magnitudes of displacements in all these intervals.

To illustrate the difference between the three quantities - position, displacement and distance travelled, consider a particle starting from position x_1 at time t_1 , travelling to the right to reach position x_2 at time t_2 and then travelling to the left to reach position x_3 at time t_3

d) Velocity:

- If a particle has displacement Δx in a time interval Δt , then the average velocity is given by

$$v_{av} = \frac{\Delta x}{\Delta t}$$

- The instantaneous velocity, which is generally referred to as velocity is given by instantaneous velocity =

$$v = \lim_{\Delta t \rightarrow 0} \frac{\Delta x}{\Delta t}$$

$$v = \frac{dx}{dt}$$

- Velocity is a vector quantity and in rectilinear motion will be represented by a scalar with positive or negative sign indicating its direction.
- The magnitude of velocity is known as speed

e) Acceleration :

- If the velocity of particle changes by Δv in a time interval Δt , the average acceleration is given by

$$a_{av} = \frac{\Delta v}{\Delta t}$$

- The instantaneous acceleration, generally referred to as acceleration is given by

$$a = \lim_{\Delta t \rightarrow 0} \frac{\Delta v}{\Delta t}$$

$$a = \frac{dv}{dt}$$

$$v = \frac{dx}{dt}$$

$$a = \frac{d^2x}{dt^2}$$

- The acceleration is a vector quantity and in rectilinear motion, it will be represented by a scalar with positive or negative sign indicating its direction.
- The term **deceleration** is used to indicate that the speed (the magnitude of v) is decreasing.
- If ' v ' and ' a ' are in same direction it is acceleration whereas if ' v ' and ' a ' are in opposite directions, there is deceleration.
- For example, when an object is thrown upwards (initial velocity upwards) then the object gets decelerated as the acceleration due to gravity is downwards. When an object is thrown downwards it gets accelerated as the initial velocity and the acceleration are both directed downwards.

- Thus if ' a ' and ' v ' have the same sign, it is acceleration and if they have opposite sign, it is deceleration.
- Problems in kinematics of rectilinear motion can be broadly classified into the following types:
 - i) Variable acceleration where functions are given relating any two of the four variables position, velocity, acceleration and time.
 - ii) Motion with constant acceleration. This type includes motion under gravity.
 - iii) Variable acceleration when functions are not known or the function changes from one-time interval to another. In such cases, motion diagrams are used which are graphs relating any two of the four variables.
 - iv) Dependent motion where variables for one object are related to variables of another object.
 - v) Relative motion.

2. Variable Acceleration

When functions relating any two of the four variables are given, use basic definitions (equations (9.1.2), (9.1.4), (9.1.5) and (9.1.6)) and differentiate or integrate the functions to obtain relations for the required variables.

- For example, if velocity is given as a function of time,

$$v = f(t)$$

then to get position ' x ' in terms of ' t ', use $v = dx/dt = f(t)$,

- Separate the variables,

$$dx = f(t) dt$$

and integrate to obtain relation between ' x ' and ' t '.

- One can use either definite or indefinite integration. If definite integration is used, to obtain an equation for x in terms of t , use limits of integration as say x_0 to x for the variable ' x ' and t_0 to t for the variable ' t ' where x_0 and t_0 are then two initial values.

$$\int_{x_0}^x dx = \int_{t_0}^t f(t)dt$$

- If indefinite integrals are used, the constant of integration has to be calculated using some given conditions and then resubstituted to get the required equation.
- If acceleration is given as a function, either $a = dv/dt$ or

$a = dv/dx$ has to be used. In such cases we have to use that equation which enables us to separate the variables.

- If $a = f_1(t)$ then $a = \frac{dv}{dt}$ has to be used. If $a = f_2(x)$ then $a = v \frac{dv}{dx}$ has to be used.
- If $a = f_3(v)$ then we have to use either $a = \frac{dv}{dt}$ or $a = v \frac{dv}{dx}$ depending upon whether a relation between 'v' and 't' is required or a relation between 'v' and 'x'.

- While solving problems, the following concepts will be useful:

i) Displacement and position are same when starting position is origin. Hence in situations where starting position is not known, it is convenient to take the starting position as origin.

ii) The magnitude of displacement is equal to distance travelled only when particle keeps travelling in the same direction.

iii) Whenever particle changes its direction in rectilinear motion, its velocity at that instant becomes zero. At the point where particle changes direction, it reaches its maximum or minimum value of position co-ordinate 'x'.

$$\square dx/dt = 0$$

$$\square v = 0$$

iv) Condition for maximum or minimum velocity is

$$dv/dt = 0, \text{ i.e., } a = 0$$

v) To calculate distance travelled, first put $v = 0$ to find whether particle changes direction or not in the given time interval.

vi) A linear relation between two variables, say when v varies linearly with t , is of the form

$$v = mt + c.$$

vii) When a vector quantity is proportional to another vector quantity, the constant of proportionality can be either positive or negative depending upon directions of the two vectors.

CURVILINEAR MOTION

The motion of a particle is said to be curvilinear when it moves along a curved path. Curvilinear motion can be either in two or three dimensions. We will be limiting our discussions only to the two dimensional curvilinear motion.

- This motion can be analyzed using rectangular components, normal and tangential components or radial and transverse components.

Position, Velocity and Acceleration in Curvilinear Motion

- For a particle moving along a curved path in a plane, the position, velocity and acceleration are vector quantities.

- Consider a particle moving along a curved path. If the **vector \vec{r}** particle is at point 'P' at time 't', then its position is defined by vector which is directed from O to P.

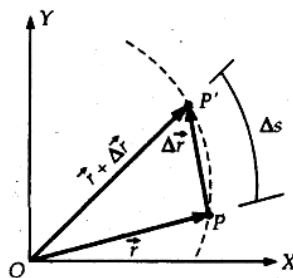

- Let the particle be at position P' at time $t + \Delta t$.

$$\vec{r} + \Delta \vec{r} \text{ where } \Delta \vec{r}$$

The position vector at P' is $\vec{r} + \Delta \vec{r}$ is the change in position i.e. displacement of the particle represented by the vector $\vec{PP'}$.

- The distance travelled Δs is the length of arc PP'.

$$\vec{v}_{av} = \frac{\Delta \vec{r}}{\Delta t}$$

will be the average velocity and the instantaneous velocity is

$$\vec{v} = \lim_{\Delta t \rightarrow 0} \frac{\Delta \vec{r}}{\Delta t} = \frac{d\vec{r}}{dt}$$

The magnitude of \vec{v} is called speed

1. A particle is projected with an initial velocity of 60 m/s, at an angle of 75° with the horizontal. Determine

- a) The maximum height attained by the particle
- b) Horizontal range of particle
- c) Time taken by the particle to reach highest point
- d) Time of flight

Solution :

a) Maximum height $H = \frac{u^2 \sin^2 \alpha}{2g} = \frac{60^2 \sin^2 75}{2 \times 9.81}$

∴ $H = 171.2 \text{ m}$

b) Horizontal range $R = \frac{u^2 \sin 2\alpha}{g} = \frac{60^2 \sin(2 \times 75)}{9.81}$

∴ $R = 183.49 \text{ m}$

c) Time taken by the particle to reach highest point is $t = \frac{T}{2} = \frac{u \sin \alpha}{g}$

∴ $t = \frac{60 \sin 75}{9.81}$

∴ $t = 5.9 \text{ s}$

d) Time of flight $T = 2t = 2 \times 5.9$

∴ $T = 11.8 \text{ s}$